

SmokeShield PTC™

CE Marked 'ES' Rated Fire/Smoke Damper



KEY FEATURES

- CE marked fulfilling the requirements of EN 15650.
- Approved by LPCB and conforms to LPS1162 issue 4.
- Fire tested to EN 1366-2.
- Classified to EN 13501-3.
- Proportional Torque Control (PTC) for optimised torque performance.
- Unique snaplock™ drive interface ensures user friendly connection of Control Mode.
- Easy connection to square, rectangular, circular and flat oval ductwork.
- Choice of tested installation methods to suit Concrete/ Masonry Floors/Walls and Dry Walls.
- Choice of electrical control modes.
- Unique and patented Electrical Thermal Release (ETR) for ultimate safety.
- ASFP Grey Book listed.
- Red Book Live Listed.
- Halogen-free low smoke and fume cabling supplied as standard.
- Actionpac damper control system compatibility.

Contents

Advantages of SmokeShield	3
Specifiers will appreciate	3
Installers will appreciate	3
Selection Guide	4
Technical Description	5
Casing Features	5
Spigot Connections.....	5
Blade Features	5
Application Parameters	5
Actuators	5
Flexible Actuator Configuration.....	5
Wiring Diagrams	6
Actuator Options	6
Actuator Specifications	6
Installation	7
SmokeShield PTC™ I/F Installation Frame	7
SmokeShield PTC™ DWFX-F Dry Wall Fix Flange and Cleats	7
SmokeShield PTC™ DWFX-C Dry Wall Fix Cleats	7
SmokeShield PTC™ S&A Sleeve & Angle.....	7
SmokeShield PTC™ SPAN	7
Technical Data	8
Tests	8
Approvals	8
Acoustic Data	8
Dimensions and Weights.....	11
Actionpac Control Systems	11
Ordering Key	12
Specification Text.....	12



Advantages of SmokeShield

The list below shows a few of the benefits enjoyed by the specifier and installer when using the Actionair SmokeShield range of dampers...





Specifiers will appreciate



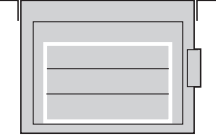
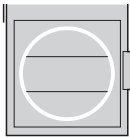
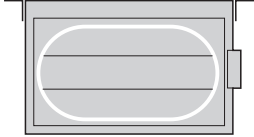

- Dedicated technical support from Swegon through the project - from start to finish and beyond.
- Cause and effect knowledge with experience and support to create a holistic design that works well for all parties.
- Wide range of sizes to suit almost all square/rectangular, flat oval and circular ductwork.
- Easy to specify, select and quote using our damper sizing and pricing tool.
- Compliance with the latest standards and legislation.
- Tried, tested and trusted product family - over forty years of damper design and manufacture in the UK.
- Easy to interface and design with the dedicated ACTIONPAC damper control systems.

Installers will appreciate

- Uses familiar installation methods, with a wide choice to suit a range of installation scenarios.
- Compact and lightweight design.
- SnapLock™ interface allows actuator purchase and install after the installation of the dampers.
- Installation support from Swegon, with years of experience and best practice.
- Easy commissioning with a dedicated specialist team available to commission alongside ACTIONPAC control panels.

Selection Guide

SPIGOT CONNECTIONS	Square / Rectangular	Circular	Flat Oval
			
Series	SS501	SS601	SS701
ACTUATORS (CONTROL MODES)	Mode 5	Mode 6	Mode 5 - 3P
			
24V (Open / Fail-Safe Close)	Y		
230V (Open / Fail-Safe Close)		Y	
24V (Open / Control / Fail-Safe Close)			Y

INSTALLATION METHOD	IF (HEVAC)	SPAN	DWFX-C	DWFX-F	DWFX-3F	Sleeve & Angle
					IMAGE PENDING	
Concrete / Masonry Wall	Yes AA/F10702			Yes AA/F10706	Yes AA/F12394 (Against Soffit)	Yes AA/F10716
In to Concrete Floor / Slab.	Yes AA/F10700	Yes AA/F12368 AA/F12864				Yes AA/F10724 (BATT)
Dry Wall Fix (Typically fixed prior to encasement by the dry wall partition).			Yes AA/F10708 AA/F10723 AA/F10730 (Against Soffit)			
Dry Wall Fix (Typcially Fixed in to existing dry wall partition).				Yes AA/F10704	Yes AA/F11945 (Against Soffit)	Yes AA/F10714
Ablative BATT infill in to dry wall partition.		Yes AA/F13214		Yes AA/F10710		Yes AA/F13276
Ablative BATT infill in to Concrete / Masony wall.		Yes AA/F13215		Yes AA/F10712		Yes AA/F13277

Technical Description

Casing Features

- With double skin spigotted galvanised steel (to BS EN 10346:2009) 1.2mm thick casing the SmokeShield PTC™ 'ES' classified Fire/Smoke dampers comply to Class A and B of Eurovent Document 2/2 and Test Procedures for Classes A, B and C of HVCA Ductwork Specification DW144.

Spigot Connections

- Damper casings are manufactured with welded spigotted connections suitable for Square / Rectangular SS501, Circular SS601 and Flat Oval SS701 duct connections.

Blade Features

- SmokeShield PTC™ damper blades are aerodynamic double skin, Type 1.4016 (430) ferritic stainless steel, which are 75mm x 0.5mm thick and interlock to form a positive smoke and fire resisting shield.
- Incorporated within the blade profile is a synthetic seal to ensure low closed blade smoke leakage.
- Stainless steel blade end bearing and peripheral gasketing maintain the low closed blade smoke leakage whilst allowing for expansion under full fire conditions.

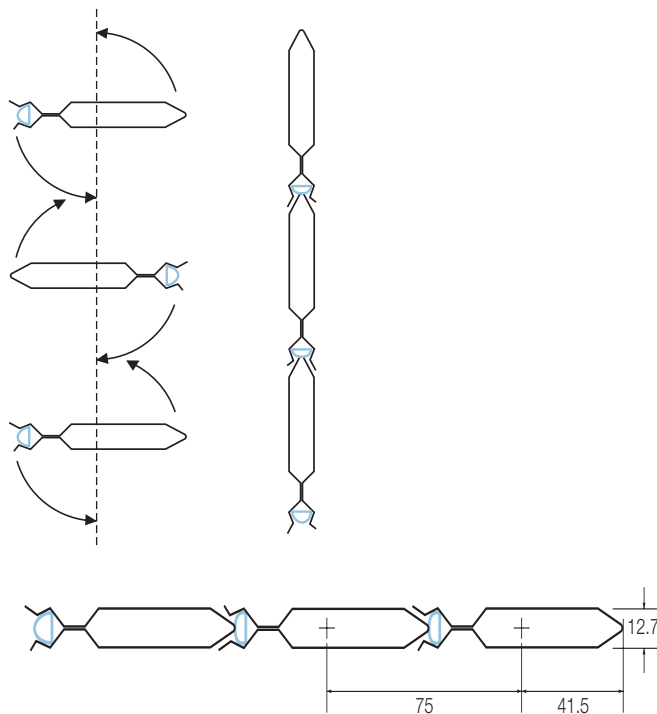

Application Parameters

- SmokeShield PTC™ 'ES' rated fire/smoke dampers to maximum width and height dimensions can be used where the operating total system pressure is up to 1500 Pascals and duct velocities to 15m/second.
- The SmokeShield PTC™ damper blades are open and fail-safe to the closed position.
- Dampers may be installed both vertically and horizontally.

- Airflow can be from either direction.
- Actionair SmokeShield PTC™ dampers are designed for applications in normal dry filtered air systems. If exposed to fresh air intakes and/or inclement conditions, the dampers should be subject to a planned inspection programme.
- As with any life safety damper product, a planned inspection programme should be implemented.
- It is recommended the product is controlled with an ACTIONPAC control panel (please see page 10).
- [For support with application or cause and effect, please contact Swegon.](#)

Actuators

Flexible Actuator Configuration

Actuators 5, 6 and 5-3P can be fitted in 3 positions through 180° allowing maximum on-site installation flexibility.

- Vertically down (Position 1)
- Horizontally (Position 2 - standard)
- Vertically up (Position 3)

This can be simply and easily carried out on site, by repositioning the location plate and actuator on to the snaplock™ Drive Interface. This flexibility ensures that the damper and actuator require the minimal amount of room.

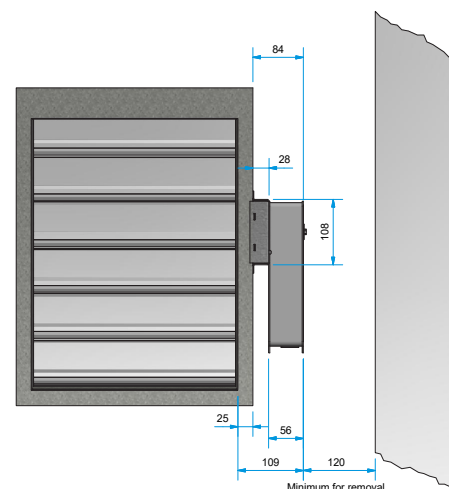

All SmokeShield actuators must be in the released position prior to connection.

Damper Actuator Interface

- The actuator operates the SmokeShield through a unique drive system. The snaplock™ Damper/Actuator Interface is a part of Automatic 'ES' classified fire/smoke damper and actuator assembly with a unique and dedicated proportional torque control for optimised damper/actuator torque performance.
- The unique snaplock™ drive interface ensures user friendly, easy and secure connection of the actuator to the damper.
- The drive interface which is totally independent of the

SmokeShield PTC

ductwork, eliminates the need for costly dedicated duct sections, and provides ease of connection to square, rectangular, circular and flat oval ductwork.

- This drive interface guarantees that only the correct and certified Actionair products can be used.

Electrical Thermal Release (ETR)

- Dampers are fail-safe by means of a unique and patented electrical thermal release which operates at approx 72 °C or if power supply is interrupted, tested to ISO10294-4 and complying with BS 9999: 2017.
- The ETR incorporates triple safety features, including an ingenious device that ensures the fail-safe status of the damper if the ETR is not fitted on to the ductwork.
- A manual test switch allows periodic operation of the damper for testing purposes simulating actual fail-safe release under smoke/fire conditions.
- For safety reasons the ETR is designed to operate once only when the activation temperature is reached.



ETR Indication light

- As standard, a green LED lamp is built into the ETR housing. This gives the user a simple and clear visual check that the actuator is receiving power, when the ETR is correctly fitted, and the thermal fuse is intact.

Wiring Diagrams

- [Please see the installation guides for wiring diagrams.](#)

Actuator Options

A choice of three standard motorised actuators are available. Other actuators to suit specialist application are available, see ordering code and contact us for more details.

Actuator Name	Behavior	Specification
M5 PTC	Thermal Release/ Power Off - Fail Safe Close	24V 10/2W (12.5VAMAX) end switches SPDT 250V 6(3)A
M6 PTC	Thermal Release/ Power Off - Fail Safe Close	230V 12/4W (14VAMAX) end switches SPDT 250V 6(3)A
M5-3P PTC	Thermal Release/ Power Off - Fail Safe Close 0-10 V set position	24V 7/2W (10VA) end switches SPDT 250V 6(3)A

The actuators are located outside of the ductwork for easy installation and access.

Modes 5, 6 and 5-3P Electrical Optimised motor/spring return actuators with remote reset-release facilities, and with volt free contacts for provision of external indication, monitoring and control by means of an Actionpac damper

control system, or by a suitable alternative proprietary control format.

Actuator Specifications

Mode 5 PTC and Mode 6 PTC

- This actuator achieves 60 seconds to drive to the end position, with a 22 second spring return time. As with all PTC modes, this series uses the snaplock™ interface. Fire rated dampers are primarily designed to be fitted into a wall or floor, and the interface displaces the mode from the line of the wall.
- Dampers may be installed and finally the mode removed from storage for easy fitting, thus preventing damage to the mode before it is required.
- End switches and LSF cable are provided as standard on these modes. Fail safe close only in accordance with the fire damper standards.

Mode 5 PTC

- The Electronic Thermal Release (ETR) supplied for fire damper use has an integral fail-safe device to ensure that it is installed into the ductwork correctly.
- End switches are provided with each mode, so that damper Reset and Release positions may be monitored
- The mode is permanently attached to the mechanism driving the damper blades.
- SmokeShield actuator M5 PTC is supplied as standard in accordance with all relevant EN regulations for fire dampers, with the Electrical Thermal Release (ETR)
- The units fail-safe by means of the unique and patented ETR device which operates at 72°C, or if the power supply is off/interrupted. Complying with BS 9999: 2017.
- One metre of halogen free low smoke and fume electric cable is also included with the actuator for convenience of on site wiring. This also provides the distinct safety advantage of all electricians terminating outside the duct, eliminating potential in-duct fire hazards from wiring faults. (Connection boxes available).
- The Electrical Thermal Release is prewired with 0.5m halogen free low smoke and fume cable on the actuator. A manual test switch fitted on the ETR allows periodic operation of damper simulating actual fail-safe release under smoke/fire conditions.

Mode 6 PTC

- The Electronic Thermal Release (ETR) supplied for fire damper use has an integral fail-safe device to ensure that it is installed into the ductwork correctly. End switches are provided with each mode, so that damper Reset and Release positions may be monitored. The mode is permanently attached to the mechanism driving the damper blades.
- SmokeShield actuator M6 PTC is supplied as standard in accordance with all relevant EN regulations for fire dampers, with the Electrical Thermal Release (ETR).
- The units fail-safe by means of the unique and

patented ETR device which operates at 72°C, or if the power supply is off/interrupted. Complying with BS 9999: 2017.

- One metre of halogen free low smoke and fume electric cable is also included with the actuator for convenience of on site wiring. This also provides the distinct safety advantage of all electricians terminating outside the duct, eliminating potential in-duct fire hazards from wiring faults. (Connection boxes available.)
- The Electrical Thermal Release is prewired with 0.5m halogen free low smoke and fume cable on the actuator. A manual test switch fitted on the ETR allows periodic operation of damper simulating actual fail-safe release under smoke/fire conditions.

Mode 5-3P PTC

- This 3 position actuator allows a damper to be moved to both the reset and release position, with the additional facility to move the damper to a third control position.
- The mode is given a 0-10V DC signal, defining the control position of the blades. A return signal 0 -10V DC is provided to allow monitoring of position. To support this actuator and allow positioning to be set local to the damper, Actionair have the Control Monitoring Stations: M5-3P (24V) & M5-3P (230V).
- As with all PTC modes, this series uses the snaplock™ interface. Fire rated dampers are primarily designed to be fitted into a wall or floor, and the interface displaces the mode from the line of the wall. Dampers may be installed and then the mode removed from storage for easy fitting, thus preventing damage to the mode before it is required.
- End switches, LSF cable, and Electronic Thermal Release (ETR) are provided as standard.
- SmokeShield Actuator M5-3P PTC is supplied as standard in accordance with all relevant EN regulations for fire dampers, with the Electrical Thermal Release (ETR)
- The units fail-safe by means of the unique and patented ETR device which operates at 72°C, or if the power supply is off/interrupted. Complying with BS 9999: 2017.

Control Monitoring of 3P acutators

3P Smoke Fire Damper Interface (3PSFDI)

- Used with the Actionpac LNS System Actuator can be set to a balanced position or driven one way and fail safe via spring return, alternatively be modulated via 2 – 10V signal from BMS.

M5 - 3P - CMS (230V)

- The M5-3P CMS this control unit gives the user the opportunity to set a control position. It provides visual (lamp) and volt free (relay) indication of damper position (Released, at Control Position, Reset).
- A terminal is provided to allow feedback of the 0 -10V DC monitoring voltage. In addition, a fire alarm input may be made (NC) which will cause the damper to release if the contact is broken.

Installation

[Full installation details are available on our website and are sent out with each damper.](#)

Actionair SmokeShield PTC has the following approved installation methods...

SmokeShield PTC™ DWFX-F Flange and Cleats

CE Marked 'ES' Rated Fire/Smoke Dampers complete with Dry Wall Fix Flange and Cleats. See DWFX-F installation document for details.

SmokeShield PTC™ DWFX-C Dry Wall Fix Cleats

CE Marked 'ES' Rated Fire/Smoke Dampers complete with Dry Wall Fix Cleats. Typically installed prior to encasement by the dry wall partition. See DWFX-C installation document for details.

SmokeShield PTC™ S&A Sleeve & Angle

CE Marked 'ES' Rated Fire/Smoke Dampers c/w Sleeve & Angle Installation Frame. Typically installed into concrete / masonry walls, floors and dry walls with use of Ablative Batt. See S&A installation document for details.

SmokeShield PTC™ SPAN

CE Marked 'ES' Rated Fire/Smoke Dampers. Typically installed in a concrete floor. See SPAN installation document for details.

FireShield™ DWFX-3F Flange and Cleats

CE Marked 'E' Rated Fire Dampers c/w Dry Wall Fix Flange and Cleats. Typically installed in to existing concrete / masonry and dry walls up against the construction edge (Soffit).

Technical Data

Tests

Seismic Qualification

SS501PTC, have been subjected to triaxial seismic qualification tests in accordance with BNFL Technical Services Report ET 372 Schedule No. Twelve, to the levels detailed in Costain Document 6733-0250-064-10-0020, Rev C, Specification for Diesel Generator and Load Bank. The testing was also in general accordance with IEEE 344-2004 IEEE Recommended Practice for Seismic Qualification of Class 1E Equipment for Nuclear Power Generating Stations – Time History Method.

Approvals

SmokeShield PTC™ Approvals:

- CE marked to Product Standard EN 15650:2010.
- Fire tested to EN 1366-2.
- Classified to EN 13501-3 – ES Rated.

Factory Production Control to EN15650. This includes...

- 20,000 cycle tested.
- Daily blade and casing leakage testing.
- Corrosion tested to EN 60068-2-52: 1996 satisfy the requirements of LPS 1162.
- Thermal fuse tested to ISO 10294-4.

CE Marking

- Low gas/smoke and fire integrity to classification ES in vertical and horizontal test installations. The SmokeShield PTC™ Damper has been tested in accordance with EN 1366- 2. It achieved ES classification in accordance with EN 13501-3. ES classification allows a maximum of 200m³/ Hr/m² (corrected to 20°C) hot gas leakage throughout the test at 300 Pa pressure differential across the damper. For full CE classification details, please see the installation drawings in the installation documentation.

LPCB

- An LPCB approved product, compliant to the new Loss Prevention Council Design Guide for Fire Protection of Buildings. Fire tested in vertical and horizontal applications under dynamic conditions by The Loss Prevention Council.

DW144

- Complies with the latest DW 144 casing leakage specification.

Electrical standards

- The Electrical Actuators satisfy requirements of the following standard(s) or other normative documents, EN 6100-6-2 / EN 6100-6-3 / EN60730-1 / EN 60730-2-14 following the provision of Directive 2004/108/EG, 2006/95/EG.
- [For full classification details, please download the declaration of performance, available on our website.](#)

Acoustic Data

- The data presented is from the Laboratory Determination of Acoustic and Aerodynamic Performance of SmokeShield PTC™ Dampers.
- A programme of extensive tests was carried out in the Reverberation Chamber and North Transmission Chamber of Sound Research Laboratories Limited, Holbrook Hall, Sudbury, Suffolk, generally in accordance with BRITISH STANDARDS Nos. 4196, 4773, 4856, 4857 and 4954.
- This independent test facility is approved under the NAMAS Scheme.
- From the selection of a duct velocity within the operational parameters of the damper, a resultant pressure drop from Graph 1 can be determined and the sum of these two components applied to the Velocity x Pressure Drop vs Sound Power Level Graph (graph 2).
- The graph is the result of a full range of acoustic tests on SmokeShield PTC™ Dampers with the blades set in their fully open position.
- The Spectrum Correction Data is applied to the number obtained from the graph and a complete sound spectrum of flow generated noise for both outlet (in duct) and breakout (casing radiated) can be obtained from Table 1.

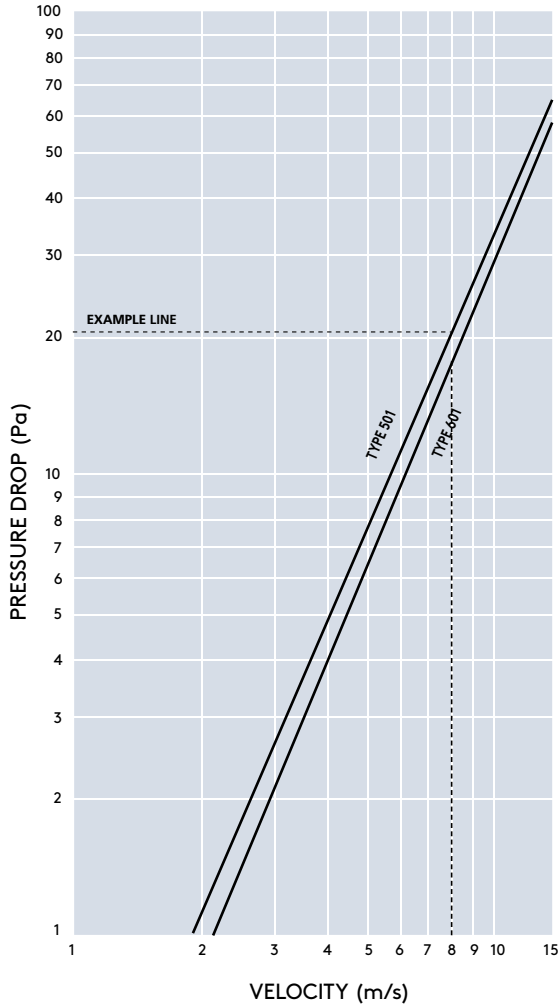

Figure 1: Pressure Drop (Pa) Vs Velocity (m/s)

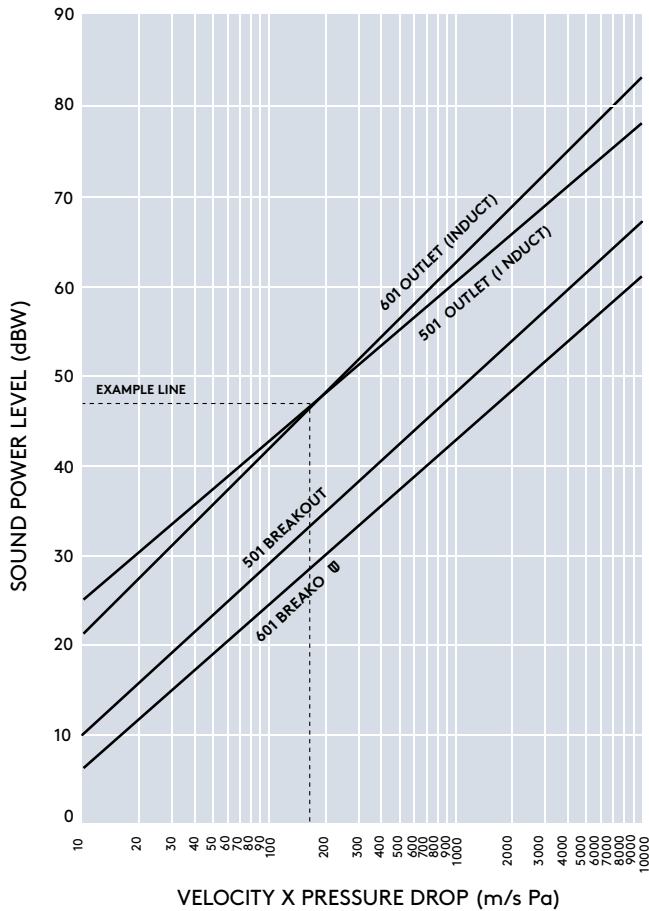

Figure 2: Velocity (m/s) X Pressure Drop (Pa) Vs Sound Power Level (dBW)

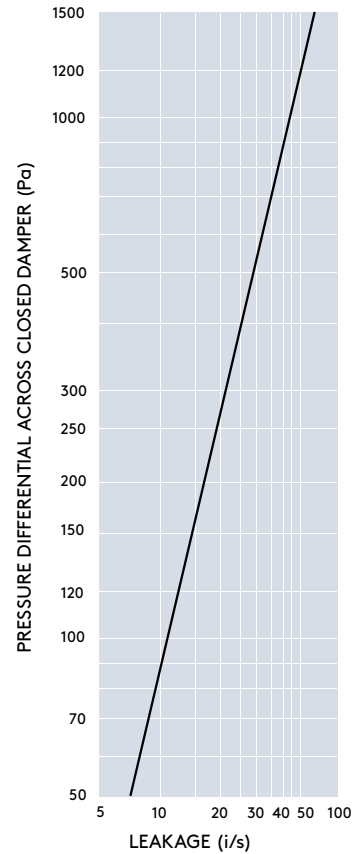

Figure 3: Damper Leakage (l/s) Vs Pressure differential across damper (Pa)

Example:

Duct with a design velocity of 8 m/sec.
SmokeShield PTC Damper Series 501 fully open.
Pressure Drop = 21 Pa (graph 1)

Multiply Velocity x Pressure Drop
 $8 \times 21 = 168$

From Sound Power Graph (graph 2) plot 168 on horizontal Velocity/Pressure axis against 501 outlet (induct) graph to obtain 47 dBW on Vertical Sound Power Level Axis. Add or subtract corrections to the 47 dBW to provide full spectrum analysis using appropriate Correction Table.







Correction Tables

SmokeShield PTC™ Outlet (Induct) Spectrum Corrections

Octave Band	Hz	63	125	250	500	1k	2k	4k	8k
Series 501	dB	5	4	5	5	3	1	-3	-5
Series 601	dB	9	4	4	5	3	1	-3	-6

SmokeShield PTC™ Breakout Spectrum Corrections

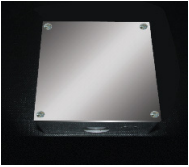
Octave Band	Hz	63	125	250	500	1k	2k	4k	8k
Series 501	dB	8	11	9	6	-3	-6	-14	-17
Series 601	dB	6	10	8	4	-3	-3	-11	-14

	<p>Damper Test Unit</p> <p>Reset (open) and release (closed) indication.</p> <p>Spring bias (power OFF) test switch.</p> <p>Power normally ON.</p>	DTU24	24V AC/DC
		DTU120	120V AC
		DTU230	230V AC
	<p>Damper Status Indicator</p> <p>Reset (open) and release (closed) indication.</p>	DSI24	24V AC/DC
		DSI120	120V AC
		DSI230	230V AC
	<p>Damper Control Unit</p> <p>Switch ON/OFF function.</p> <p>Reset (open) and release (closed) indication.</p>	DCU24	24V AC/DC
		DCU120	120V AC
		DCU230	230V AC
	<p>Damper Release and Indication Module (DRIM)</p> <p>This is designed for control and monitoring of the electrically operated Smoke Shield PTC™ Fire and Smoke dampers.</p> <p>It will operate from 24V, 120V or 230V supplies, 50 or 60 Hz.</p> <p>Selection of the operating voltage is by use of internal links on the PCB, prior to installation and connection of actuator and supply.</p>	DRIM	24V – 230V AC/DC
	Damper Connection Box (All Voltages).	DCB	24V – 230V AC/DC
	M5-3P – CMS (24V) Control Unit	M53PCMS	24V AC/DC
	M5-3P – CMS (230V) Control Unit	230V M53PCMS	230V AC

Dimensions and Weights

Dimensions

- SmokeShield PTC™ is available in a range of sizes to fit ducts from 100mm x 100mm to 1000mm x 1000mm (available in 1mm increments for both width and height between the minimum and maximum sizes).

Weights

- Weights below are approximate and measure in KG based on square dampers.
- Weights provided exclude actuator and thermal enclosure. For total weights please add 4.4KG for the actuator.

Square or Circular Duct Size (mm)	100	150	200	250	300	350	400	450	500	550	600	650	700	750	800	850	900	950	1000
Series 501 Square	3.4	3.4	3.4	4.2	4.8	5.6	6.5	7.4	8.6	9.6	10.8	12.4	13.6	14.9	16.2	17.7	19.2	20.8	23.5
Series 501 Square + I/F	6.2	6.2	6.2	7.4	8.7	10.3	11.9	13.2	14.6	16.3	18.5	20.5	22.1	24.0	25.9	28.1	30.3	32.4	34.5
Series 601 Circular	5.3	5.3	5.3	6.1	7.2	8.4	9.6	11.2	12.6	14.0	15.9	17.5	19.1	20.7	22.5	24.3	26.2	29.3	32.1
Series 601 Circular + I/F	8.5	8.5	8.5	10.0	11.9	13.7	15.4	17.1	19.2	21.8	24.0	26.0	28.2	30.4	32.8	35.3	37.8	40.3	43.1

Actionpac Control Systems

Our Actionpac control systems have been designed with the user in mind, providing an advanced tool that simplifies installation and commissioning of dampers like SmokeShield PTC™ and peripheral devices. The embedded computer utilises solid state technology for optimum reliability.

Its server architecture delivers benefits such as reduced commissioning time, simplified operation and scope for future growth and complete flexibility.

[To learn more please visit our website.](#)

Ordering Key

SmokeShield

SS501/PTC - SmokeShield Square or Rectangular (Fail-safe closed)

SS601/PTC - SmokeShield Circular (Fail-safe closed)

SS701/PTC - SmokeShield Flat Oval (Fail-safe closed)

a b c d

Installation:

DWFX-F - Dry Wall Fixing System Flange plus Cleats

DWFX-C - Dry Wall Fixing System Cleats

I/F - HEVAC / HVCA Installation Frame

S&A - Sleeve and Angle

SPAN

DWFX-3F Flange and Cleats

Duct Size:

600(W) x (H)450

Actuator

M5-PTC - 24V 10W (12.5VA)

M6-PTC - 230V 12W (14VA)

M5-3P-PTC - 24V 7W (10VA)

Schischek*

InMax 15-BF1*

InMax 15*

RedMax 15-BF1*

RedMax 15*

ExMax 15-BF1*

ExMax 15*

Accessories

DTU - Damper Test Unit

DSI - Damper Status Indicator

DCU - Damper Control Unit

DRIM - Damper Release and Indication Module

DCB - Connection Box For Control Mode 5, Mode 5-3P and Mode 6

M5-3P-CMS - Damper Control Unit

230V M5-3P-CMS Damper Control Unit

**optional actuator for specialist applications, please contact us for more details*

Example:

SS501/PTC-DWFX-F-300x300-M5-PTC-DTU

Specification Text

SmokeShield PTC™ Proportional Torque Control, CE Marked 'ES' Rated Fire/Smoke Dampers. Opposed bladed with 75mm x 0.5mm thick stainless steel aerodynamic interlocking blades incorporating synthetic seal, with steel blade end bearings and peripheral gasketing. Housed in a galvanised steel fully welded 1.2mm spigotted casing suitable for square, rectangular, circular or flat oval connections.

The totally enclosed precise movement opposed blade drive shall be positioned out of airstream for protection against damage, be hard wearing and free running.

The Control Mode/Damper connection shall be by means of the snaplock™ drive interface mechanism, which is totally independent of the ductwork.

SmokeShield PTC™ 'ES' Rated Fire Dampers with their appropriate control modes shall have spring Fail-Safe Closed operation only, with selected Control Mode (M5 24V, M6 230V, M5 - 3P 24V) as supplied by Actionair.