



Product manual

# Variable air volume damper

RVP-C

Airflow regulation

Version 1.0.5  
Date: 13.12.2021.

## RVP-C

RVP-C ensures volume flow control regulation by a given set-point. Set-point can be given as air volume flow or overpressure/underpressure. Parametrization is carried out in the factory in accordance with clients request. Advantages of variable air volume dampers are high regulation precision and no maintainance required.



- ▼ [Product overview](#)
- ▼ [Installation](#)
- ▼ [Controllers](#)
- ▼ [Accessories](#)
- ▼ [Parametrization](#)
- ▼ [Diagrams](#)
- ▼ [Maintenance](#)



### PRODUCT OVERVIEW

### AIRFLOW REGULATION

#### DESCRIPTION

VAV dampers are used to control a variable or constant airflow volume in duct ventilation systems. All VAV dampers are equipped with compact VAV actuator, which has in-built pressure differential sensor and PID logic control. Actuator sensor is connected with rubber hoses to the measuring cross which is used for measuring the duct airflow. By having a real time information about the volume airflow in the duct, VAV's can dynamically respond to the changes in the setpoint (temperature, CO2 or humidity) and ensure optimized ventilation with lowest possible energy consumption.

#### MATERIALS

Casing and damper blade of the VAV damper are produced out of galvanized steel sheet. Sealing gaskets are produced out of EPDM rubber, and measuring cross is made out of aluminium tubes. On special demand, VAV casing can be produced out of stainless steel sheet EN 1.4301/EN 1.4491/EN 1.4404 (AISI 304/316/316L) and can also be powdercoated to any standard RAL chart colour.

#### DIMENSIONS

øDn [mm]	L [mm]	øDz [mm]	Lz [mm]	Vmin [m³/h]	Vmax [m³/h]
100	400	198	330	37	343
125	400	223	330	54	540
160	400	258	330	90	900
200	400	298	330	145	1459
250	500	348	430	217	2215
315	600	413	530	380	3680
355	600	453	530	482	4275
400	600	498	530	615	6047
500	800	598	740	973	9484
630	850	728	810	1435	12482

\*Maximum volume flow at velocity  $v_{max} = 12$  m/s

\*\* Size 630 comes with reinforcement ring

Type	ød 100 - ød 500	ød 630
MF	Belimo LMV-D3-MF	-
SGB	Siemens GDB181.1E/3	Siemens GLB181.1E/3
MP	Belimo LMV-D3-MP	Belimo NMV-D3-MP
MOD-S	Siemens GDB181.1E/MO	Siemens GLB181.1E/MO
MOD/BAC	Belimo LMV-D3-MOD/BAC	Belimo NMV-D3-MOD/BAC
KNX-S	Siemens GDB181.1E/KN	Siemens GLB181.1E/KN
KNX-B	Belimo LMV-D3-KNX	Belimo NMV-D3-KNX
BAC	Siemens GDB181.1E/BA	Siemens GLB181.1E/BA
PP	Gruner 327VM-024-05	Gruner 327VM-024-10



- ▼ [Product overview](#)
- ▼ [Installation](#)
- ▼ [Controllers](#)
- ▼ [Accessories](#)
- ▼ [Parametrization](#)
- ▼ [Diagrams](#)
- ▼ [Maintenance](#)

## TESTS AND CERTIFICATES

All our dampers are submitted to a number of tests by official test institutes. Reports of these tests form the basis for the approvals of our dampers. Klimaoprema VAV dampers are also suitable for installation in buildings with high hygienic demands such as hospitals, clinics and pharmaceutical areas.

To confirm this, our products are tested by an independent Institute of Hygiene, based in Gelsenkirchen, Ruhr, and comply with directives and guidelines in VDI 6022.

For more information about certificates, visit our website:

[www.klimaoprema.com/rvp-c](http://www.klimaoprema.com/rvp-c)

Declaration of incorporation:



[www.klimaoprema.com/rvp-c/doi](http://www.klimaoprema.com/rvp-c/doi)

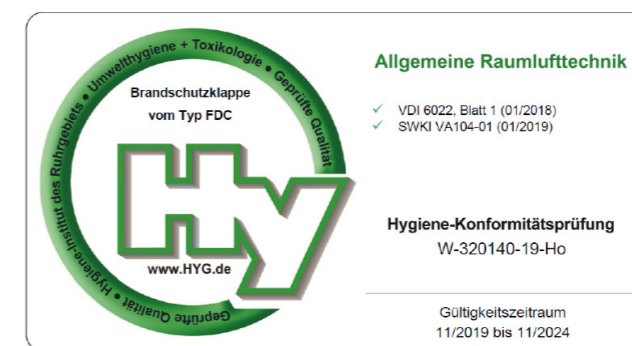

## TECHNICAL DATA



VAV damper casing is manufactured from galvanized steel sheet, but on demand can be produced out of:

- Galvanized steel and powder coated
- Stainless steel EN 1.4301/EN 1.4491/EN 1.4404 (AISI 304/316/316L)
- Stainless steel EN 1.4301/EN 1.4491/EN 1.4404 (AISI 304/316/316L) and powder coated

VAV damper for areas with potentially explosive atmospheres are also available!

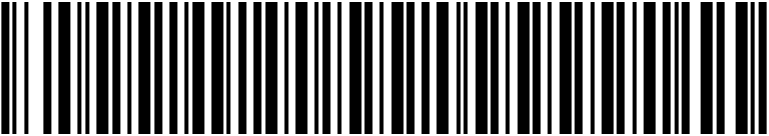

Gradna 78 A  
10430 Samobor  
Hrvatska – Croatia  
www.klimaoprema.comtel: + 385 1 3362 513

2	SERIAL NUMBER: 200385900200001	PRODUCTION DATE: 12.07.2021	3
4	TYPE: RVP-C-125-MP	WORKSHEET: 2003859	5
6	CUSTOMER:	ALT. TYPE:	
7	FACILITY: POSITION:		
8	SETTINGS: Vmin = 26 m3/h Vmin = 9.81% Vmax = 265 m3/h Vmax = 100.00% Vnom = 265 m3/h		
9	DRIVE: Motor LMV-D3-MP	USER MANUAL	
10	CONTROL SIGNAL: 2-10 VDC		13
11	REGULATION TYPE Constant		
12			
	 200385900200001		14



- [▼ Product overview](#)
- [▼ Installation](#)
- [▼ Controllers](#)
- [▼ Accessories](#)
- [▼ Parametrization](#)
- [▼ Diagrams](#)
- [▼ Maintenance](#)



PRODUCT OVERVIEW

AIRFLOW REGULATION

### Product label

- 1 - Company info
- 2 - Serial number
- 3 - Production date
- 4 - Type
- 5 - Worksheet
- 6 - Customer
- 7 - Installation location
- 8 - Parametrization
- 9 - Actuator
- 10 - Control signal
- 11 - Regulation type
- 12 - Air flow direction
- 13 - User manual link
- 14 - Barcode

### Product specifications

Nominal sizes RVP-C	ød100 - 630 [mm]
Casing length	400 - 850 mm
Temperature range	0 °C ... 50 °C
Volume flow rate range	up to 12482 m³/h
Differential pressure range	up to 1000 Pa
Casing air leakage	Class C, EN 1751
Closed blade air leakage	Class 3, EN 1751
Upstream velocity	< 12 m/s
EC conformity	EN ISO 12100:2010
Declaration of incorporation	Doi 419/2020_03_EN

## MODELS

### VAV dampers with compact controllers

These regulators are equipped with compact VAV controllers which include actuator, controller and dynamic pressure sensor in the same device.

VAV units are called pressure independent when the air flow rate passing through it is maintained constant regardless of variations in the system supply pressure. This level of control is possible with the addition of air-flow sensor (measuring cross) and variable air controller that maintains the airflow according to required set-point. The controller is measuring the airflow through the device and modulates the damper blade angle in response to system disturbances. The preset volume can be varied between calibrated airflow limits ( $V_{min}$ ,  $V_{max}$ ) via input control signal (analog, communication protocol) provided by room thermostat or HVAC BMS system.



- ▼ [Product overview](#)
- ▼ [Installation](#)
- ▼ [Controllers](#)
- ▼ [Accessories](#)
- ▼ [Parametrization](#)
- ▼ [Diagrams](#)
- ▼ [Maintenance](#)



Pressure independent regulation ensures economical distribution of air volume to the ventilated spaces according to the individual space requirements. A wide range of actuators are available with VAV dampers (Belimo, Gruner and Siemens), and a wide range of communication protocols are supported by them (MP-Bus, KNX, ModBus, Bacnet).

Dynamic pressure sensors have operating range 0..600Pa, with  $\pm 1$ Pa resolution.

Maximum operating duct pressure is 1000Pa. Casing can also be additionally insulated with 50mm of mineral wool and double skin galvanized sheet casing for reduction of the casing radiated noise. The damper blade and the connection sleeves are equipped with rubber gaskets. ATEX rated version is available and equipped with EX rated Schischek actuators and controllers.

## Controllers

### Analogue communication

Compact VAV controllers controlled via 0(2)..10V analogue signal. All controllers are equipped with feedback signal for common functions like actual flow, pressure drop or damper blade angle.

### MP-Bus communication

MP-Bus is a simple sensor/actuator bus, which is used for certain sub-systems of building automation systems. MP-Bus uses a master/slave bus technology where defined number of slave units can be connected to an MP-Master unit.

### Communication protocols

Compact controllers are also available with support for most common communication protocols: ModBus, Bacnet and KNX. Communication protocols enable connection of much larger number of units to a common communication network. Network is controlled by a building management system (BMS) controller.

### Schischek EX

ATEX rated VAV dampers are equipped with Schischek ExMax actuators and ExReg volumetric/pressure controllers. Optionally, casing can be produced in EN 1.4301/EN 1.4491/EN 1.4404 (AISI 304/316/316L) stainless steel.

## ORDERING KEY RVP-C

(1) Model	(2) Dimensions	(3) Communication type	(4) Insulation
<b>RVP-C</b>	- <b>øD</b> -	<b>MP</b>	<b>Z</b>
(1) <b>RVP-C</b> - Cylindrical VAV damper	(2) <b>øD</b> - Nominal diameter	(3) Communication type: <b>MP</b> - Belimo MP <b>MF</b> - Belimo analogue (0..10V) <b>SGB</b> - Siemens analogue (0..10V) <b>MOD-S</b> - Siemens Modbus <b>MOD-BAC</b> - Belimo Modbus / Bacnet <b>MOD-G</b> - Gruner Modbus	(4) <b>Z</b> - 50 mm mineral wool insulation <b>KNX-S</b> - Siemens KNX <b>KNX</b> - Belimo KNX <b>BAC</b> - Siemens Bacnet <b>PP</b> - Gruner analogue (0..10V)

## RVP-C with Belimo controller

Volume flow control regulation by a given set-point. Factory parametrization in accordance with clients request.

- High regulation precision.
- No maintainance required.
- Airtightness classes according to EN 1751, C 3
- Hygiene certificate according to VDI 6022.



- ▼ [Product overview](#)
- ▼ [Installation](#)
- ▼ [Controllers](#)
- ▼ [Accessories](#)
- ▼ [Parametrization](#)
- ▼ [Diagrams](#)
- ▼ [Maintenance](#)

### OPTIONS

Constant, variable, 3-stage control  
Single, master-slave and parallel modes of operation  
Insulated casing (50 mm)

- MP** - Belimo MP
- MF** - Belimo analogue (0..10V)
- MOD-BAC** - Belimo Modbus / Bacnet
- KNX-B** - Belimo KNX

RVP-C

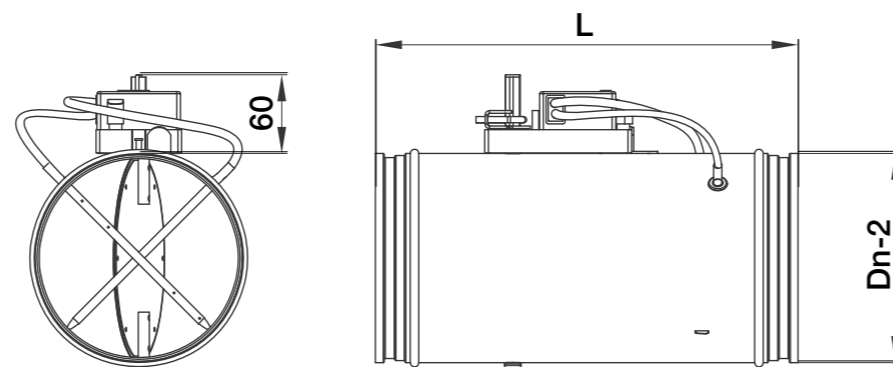

RVP-C-Z  
(Insulated casing)

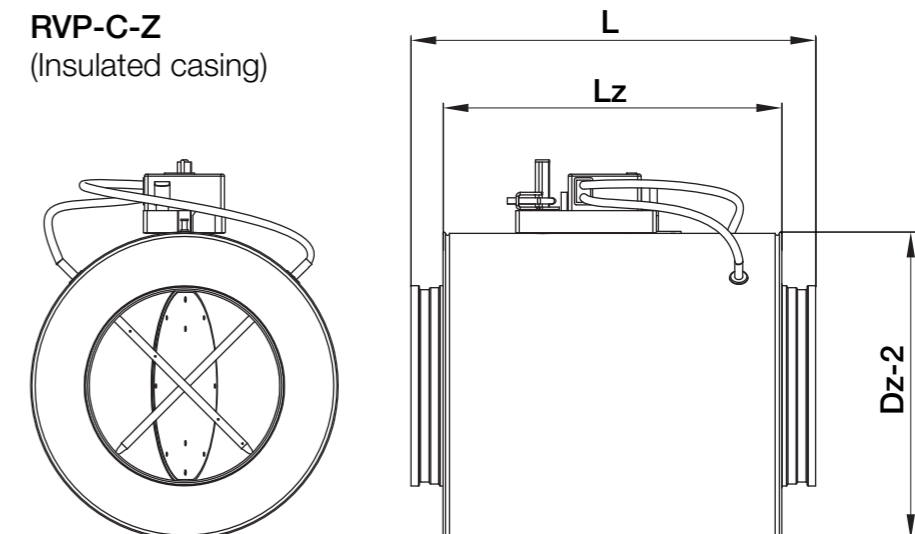

## RVP-C with Gruner controller

Volume flow control regulation by a given set-point. Factory parametrization in accordance with clients request.

- High regulation precision.
- No maintainance required.
- Airtightness classes according to EN 1751, C 3
- Hygiene certificate according to VDI 6022.



- ▼ [Product overview](#)
- ▼ [Installation](#)
- ▼ [Controllers](#)
- ▼ [Accessories](#)
- ▼ [Parametrization](#)
- ▼ [Diagrams](#)
- ▼ [Maintenance](#)

### OPTIONS

Constant, variable, 3-stage control  
Single, master-slave and parallel modes of operation  
Insulated casing (50 mm)

**PP** - Gruner analogue (0..10V)  
**MOD-G** -Gruner Modbus

RVP-C

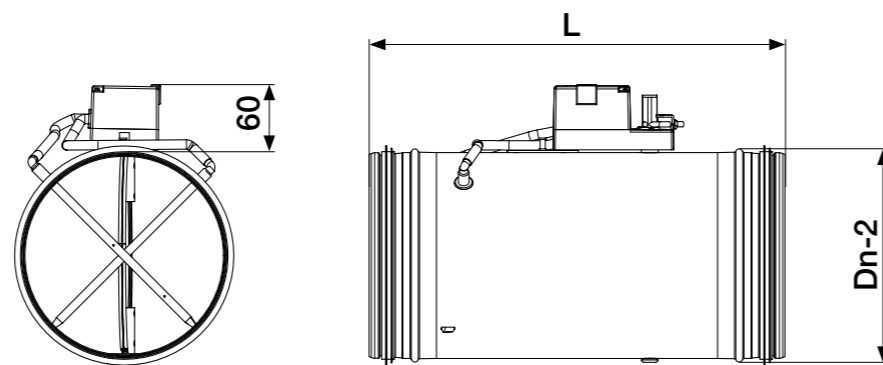

RVP-C-Z  
(Insulated casing)

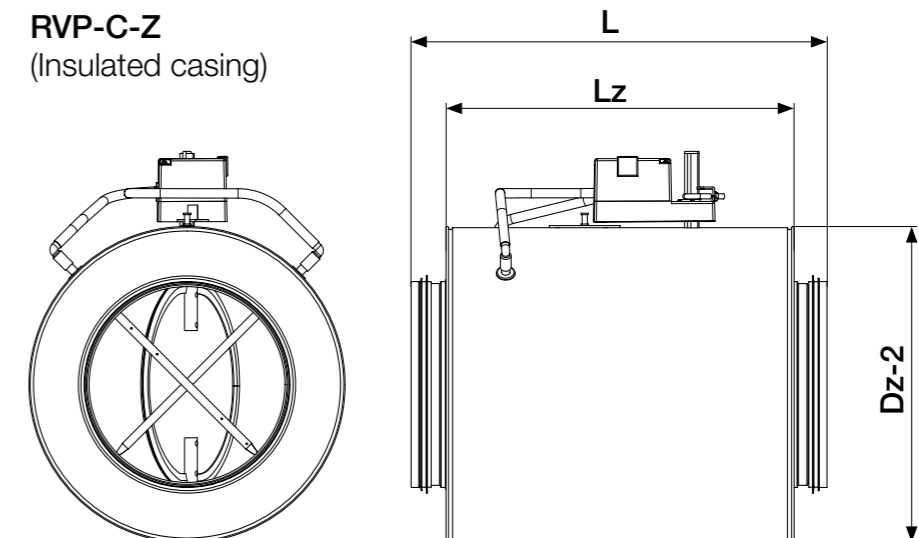

## RVP-C with Siemens controller

Volume flow control regulation by a given set-point. Factory parametrization in accordance with clients request.

- High regulation precision.
- No maintainance required.
- Airtightness classes according to EN 1751, C 3
- Hygiene certificate according to VDI 6022.



- ▼ [Product overview](#)
- ▼ [Installation](#)
- ▼ [Controllers](#)
- ▼ [Accessories](#)
- ▼ [Parametrization](#)
- ▼ [Diagrams](#)
- ▼ [Maintenance](#)

### OPTIONS

Constant, variable, 3-stage control  
Single, master-slave and parallel modes of operation  
Insulated casing (50 mm)

- KNX-S** - Siemens KNX
- BAC** - Siemens Bacnet
- SGB** - Siemens analogue (0..10V)
- MOD-S** - Siemens Modbus

RVP-C

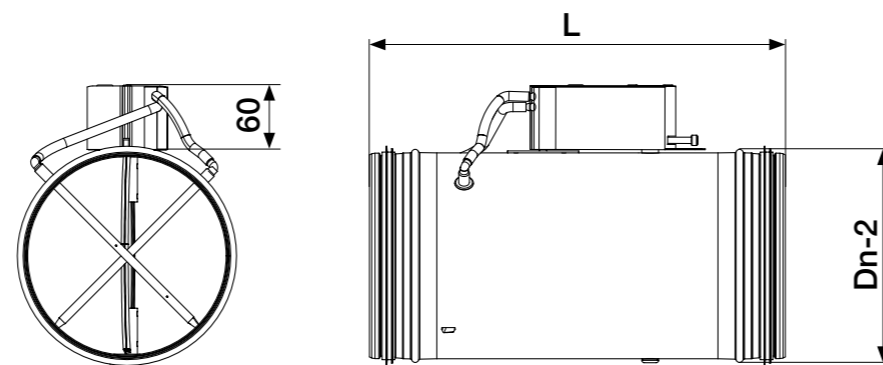

RVP-C-Z  
(Insulated casing)

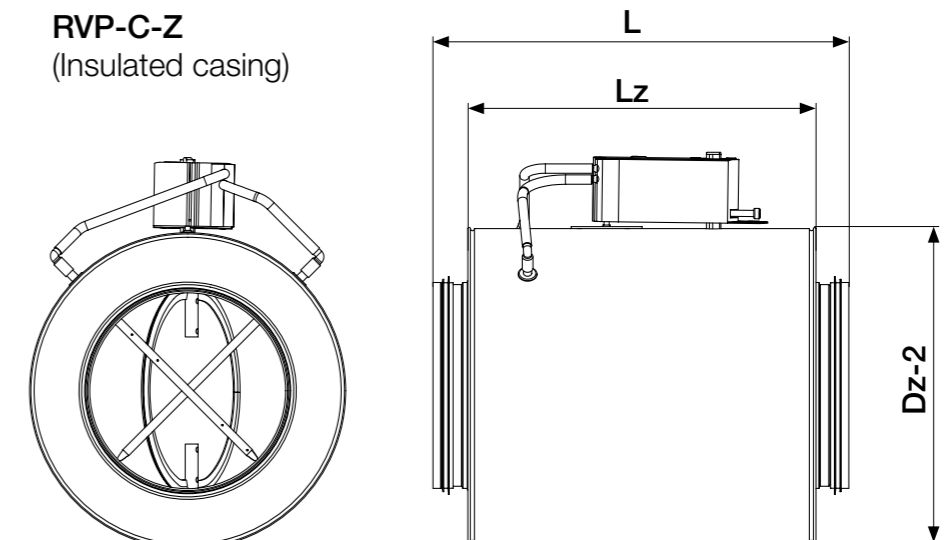



## RVP-C-EX

Volume flow control regulation by a given set-point. Factory parametrization in accordance with clients request High regulation precision.

- No maintainance required
- Designed for all gases, mists and vapours in zones 1 and 2, with electronic control additionally for dusts in zones 21 and 22
- Closed blade air leakage to EN 1751, up to class 4
- Casing air leakage to EN 1751, class C

### For more details:

- (1) [Schischek ExMax spring return actuators](#)  
 (2) [ExReg-V VAV controllers](#)



1 Schischek ExMax spring return actuator

2 ExReg-V VAV controller

- ▼ [Product overview](#)
- ▼ [Installation](#)
- ▼ [Controllers](#)
- ▼ [Accessories](#)
- ▼ [Parametrization](#)
- ▼ [Diagrams](#)
- ▼ [Maintenance](#)

### DESCRIPTION

VAV units for potentially explosiosive atmospheres are equipped with Schischek ExMax spring return actuators (1) and ExReg-V VAV controllers (2). ExReg-V controllers can be parametered on-site using menu navigation, without any electronic aids. The internal PID control structure is easy to use and can be configured fully automatically for standard applications. The display indicated the current status for actual value, setpoint value and control variable during operation.

Type Examination Certificate Number: FIDI 21 ATEX D060. Equipment complies with the essential health and safety requirements relating to the design and construction of equipment intended to use in potentially explosive atmospheres given in annex VIII of the directive ATEX 2014/34/EU.

### MATERIALS

Casing and damper blade of the VAV damper are produced out of galvanized steel sheet. Sealing gaskets are produced out of EPDM rubber, and measuring cross is made out of aluminium tubes. On special demand, VAV casing can be produced out of stainless steel sheet EN 1.4301/EN 1.4491/EN 1.4404 (AISI 304/316/316L), and can also be powdercoated to any standard RAL chart colour.

### ORDERING KEY RVP-C-EX

(1) Model	(2) Actuator/ controller	(3) Dimensions	(4) Insulation
RVP-C	EX	øD	Z
(1) RVP-C - Cylindrical VAV damper	(2) EX - Schischek ExMax + ExReg-V EX-F - Schischek ExMax with spring return + ExReg-V	(3) øD - Nominal diameter	(4) Z - 50 mm mineral wool insulation

### CLASSIFICATION ATEX RATED VAV ACTUATORS

Ex II 2G Ex h IIC T6 Gb

Ex II 2D Ex h IIIC T80°C Db

For more information about Ex classification, visit website: [ATEX classification](#)

Compact VAV solutions									
	Belimo L(N)MV-D3-MF	Belimo L(N)MV-D3-MP	Belimo L(N)MV-D3-MOD	Belimo L(N)MV-D3-KNX	Siemens GL(D)B181.1E/3	Siemens GL(D)B181.1E/MO	Siemens GL(D)B181.1E/KN	Siemens GL(D)B181.1E/BA	Gruner 227VM-024-05(10)
<b>Applications</b>									
VAV/CAV control	•	•	•	•	•	•	•	•	•
<b>Actuators</b>									
Torque	5(10) Nm	5(10) Nm	5(10) Nm	5(10) Nm	5(10) Nm	5(10) Nm	5(10) Nm	5(10) Nm	5(10) Nm
Running time	Variable	Variable	Variable	Variable	Variable	Variable	Variable	Variable	Variable
<b>Control</b>									
0/2..10V	•	•			•				•
Via contacts (CAV)	•	•							•
MP-Bus		•							
Modbus RTU			•			•			
KNX				•			•		
Bacnet								•	
PP Bus									•
<b>Pressure sensor</b>									
	0..450Pa	0..450Pa	0..450Pa	0..450Pa	0..300Pa	0..300Pa	0..300Pa	0..300Pa	0..250Pa
<b>Accessories</b>									
KOER Codis E35-VAV	•	•			•			•	•
Room temperature controller / CR24..	•	•							
Fan optimiser / COU24-A-MP	•	•							
MP gateways / UK24xxx	•	•							
PC Tool / MFT-P	•	•	•	•					
Service tool / ZTH-GEN	•	•	•	•					
Siemens software ASC941					•	•	•	•	
AST20					•	•	•	•	
<b>Supply / Inputs</b>									
AC/DC 24V	•	•	•	•	•	•	•	•	•
Feedback signal	Airflow / Damper position / Δp	Airflow / Damper position / Δp	Modbus / Not relevant	KNX / Not relevant	Airflow	Modbus / Not relevant	KNX / Not relevant	Bacnet / Not relevant	Airflow

\*if not otherwise specified, regulator is set to standard factory values  $V_{max}$  and  $V_{min}$ .

- ▼ [Product overview](#)
- ▼ [Installation](#)
- ▼ [Controllers](#)
- ▼ [Accessories](#)
- ▼ [Parametrization](#)
- ▼ [Diagrams](#)
- ▼ [Maintenance](#)

**PRODUCT OVERVIEW**

## VAV universal components

- (A) VOLUMETRIC FLOW CONTROL**  
Standard VAV casing equipped with VRU-D3-BAC controller/pressure sensor and standard modulating, fast-acting or spring return actuator. Casing is equipped with measuring cross for airflow measurement and control in the duct.
- (B) DUCT PRESSURE CONTROL**  
Damper casing without measuring cross, equipped with duct pressure controller and static sensor VRU-M1-BAC. Static pressure probe is installed on the duct, and static pressure is maintained inside the duct.
- (C) ROOM PRESSURE CONTROL**  
Damper casing without measuring cross, equipped with duct pressure controller and static sensor VRU-M1R-BAC. Static pressure probe is installed in the room and in the reference area. Static overpressure or underpressure is maintained in the room.

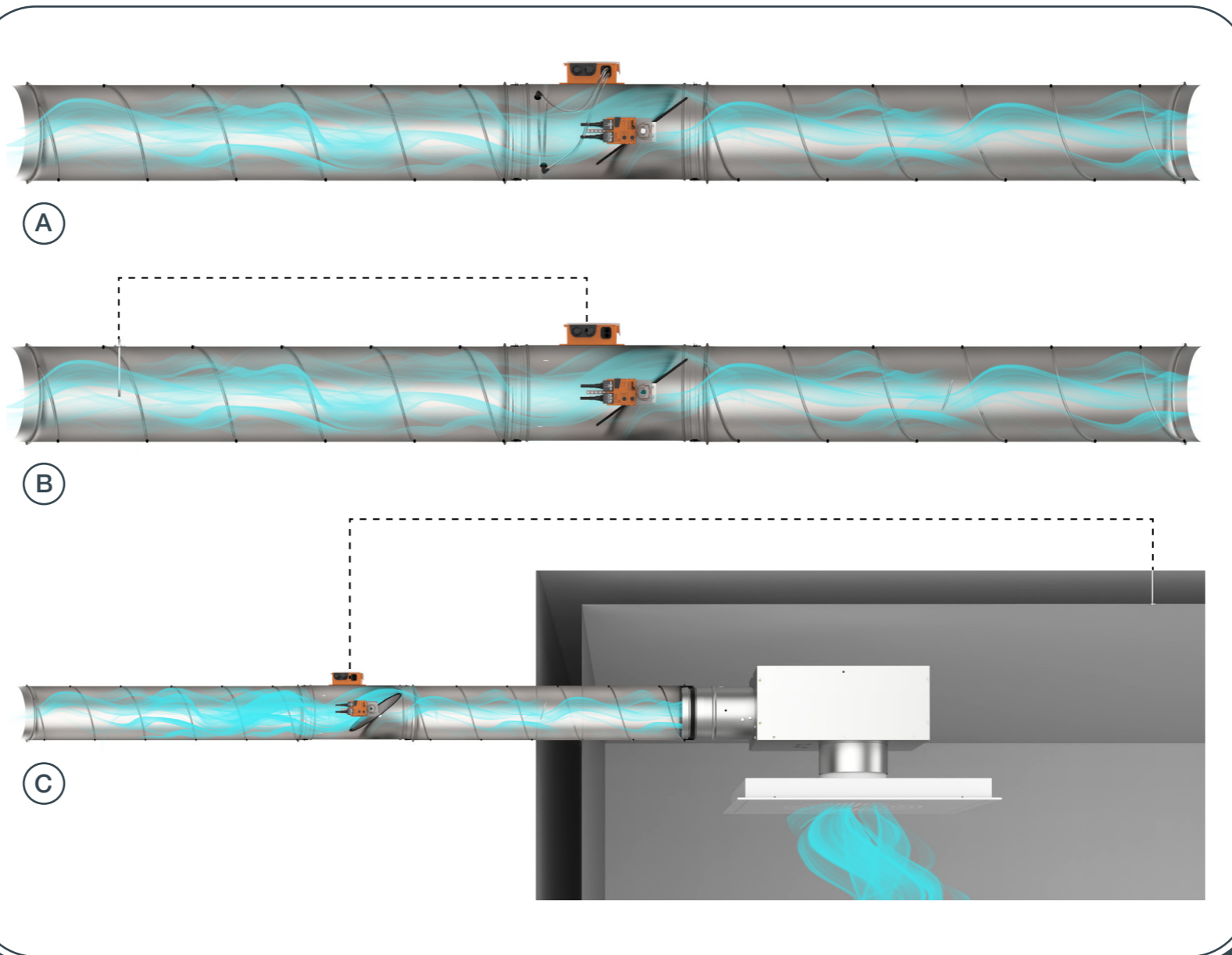

- ▼ [Product overview](#)
- ▼ [Installation](#)
- ▼ [Controllers](#)
- ▼ [Accessories](#)
- ▼ [Parametrization](#)
- ▼ [Diagrams](#)
- ▼ [Maintenance](#)

## VARIANTS

### VAV universal components

VAV components offer modular product range capable of volumetric or pressure control in duct or rooms.

Two types of sensors are available, D3 dynamic sensor and M1 diaphragm static pressure sensor. D3 sensor is used in relatively clean ventilation systems whereas diaphragm sensor is used for polluted air systems.

Multiple casing options are therefore available to provide a basis for components and actuators.

There are three types of casings that can be ordered:

- WA - RVP casing with measuring cross and damper blade without actuator
- WMC - RVP casing without measuring cross and actuator but with damper blade
- MC - measuring cross only

Three different sensor and controller types are available:

- VRU-D3-BAC - duct pressure/volume controller with dynamic D3 pressure sensor
- VRU-M1-BAC - duct pressure/volume controller with M1 static pressure sensor for duct pressure control
- VRU-M1R-BAC - pressure controller with M1 static pressure sensor for room pressure control

There types of actuators are available:

- Standard modulating actuator
- Fast acting modulating actuator
- Spring return modulating actuator

Integrated NFC interface for simple commissioning and configuration with a smartphone using the Belimo Assistant App

### ORDERING KEY RVP-C

(1) Variable air volume damper	(2) Casing type	(3) Dimensions	(4) Actuator type	(5) Controller type	(6) Insulation
<b>RVP-C</b>	- <b>WA</b>	- <b>øD</b>	- <b>M</b>	- <b>D3</b>	- <b>Z</b>
(1) <b>RVP-C</b>	(2) <b>WA</b> - standard VAV casing <b>WMC</b> - casing without measuring cross <b>MC</b> - only measuring cross	(3) <b>øD</b> - nominal diameter	(4) <b>M</b> - standard VAV actuator <b>MQ</b> - fast acting VAV actuator <b>F</b> - spring return VAV actuator	(5) <b>D3</b> - dynamic pressure controller <b>M1</b> - static duct pressure controller <b>M1R</b> - static room pressure controller	(6) <b>Z</b> - 50 mm mineral wool casing insulation

## Pressure VAV system components

Component	Description	Documentation
VRU-D3-BAC	Modbus RTU, Bacnet MS/TP, MP-Bus, dynamic pressure sensor 0...500Pa Volume flow applications	<a href="#">Technical sheet</a>
VRU-M1-BAC	Modbus RTU, Bacnet MS/TP, MP-BUS, static sensor 0...600Pa Duct pressure applications	<a href="#">Technical sheet</a>
VRU-M1R-BAC	Modbus RTU, Bacnet MS/TP, MP-BUS, static sensor -75...+75Pa Room pressure applications	<a href="#">Technical sheet</a>
LM24A-VST	VAV-Universal, ready-to-connect damper actuator for VAV and CAV units in technical building installations • Torque motor 5 Nm • Nominal voltage AC/DC 24 V • Control communicative PP	<a href="#">Technical sheet</a>
NM24A-VST	VAV-Universal, ready-to-connect damper actuator for VAV and CAV units in technical building installations • Torque motor 10 Nm • Nominal voltage AC/DC 24 V • Control communicative PP	<a href="#">Technical sheet</a>
SM24A-VST	VAV-Universal, ready-to-connect damper actuator for VAV and CAV units in technical building installations • Torque motor 20 Nm • Nominal voltage AC/DC 24 V • Control communicative PP	<a href="#">Technical sheet</a>
LMQ24A-VST	VAV-Universal, ready-to-connect damper actuator for VAV and CAV units in technical building installations • Torque motor 4 Nm • Nominal voltage AC/DC 24 V • Control communicative PP • Running time motor 2.5 s	<a href="#">Technical sheet</a>
NMQ24A-VST	VAV-Universal, ready-to-connect damper actuator for VAV and CAV units in technical building installations • Torque motor 8 Nm • Nominal voltage AC/DC 24 V • Control communicative PP • Running time motor 4 s	<a href="#">Technical sheet</a>
NF24A-VST	Ready-to-connect rotary actuator fail-safe for VAV and CAV units in technical building installations • Torque motor 10 Nm • Nominal voltage AC/DC 24 V • Control communicative PP • Spring return	<a href="#">Technical sheet</a>
SF24A-VST	Ready-to-connect rotary actuator fail-safe for VAV and CAV units in technical building installations • Torque motor 20 Nm • Nominal voltage AC/DC 24 V • Control communicative PP • Spring return	<a href="#">Technical sheet</a>
NKQ24A-VST	Ready-to-connect actuator with fail-safe for VAV and CAV units in technical building installations • Torque motor 6 Nm • Nominal voltage AC/DC 24 V • Control communicative PP • Running time motor 4 s	<a href="#">Technical sheet</a>



- ▼ [Product overview](#)
- ▼ [Installation](#)
- ▼ [Controllers](#)
- ▼ [Accessories](#)
- ▼ [Parametrization](#)
- ▼ [Diagrams](#)
- ▼ [Maintenance](#)



PRODUCT OVERVIEW

	Application					Sensor	Control				Tool		
	VAV/CAV	Air duct pressure	Room pressure	Comfort zone	Polluted air	Sensor type	0...10 / 2...10 V	MP-Bus®	Modbus RTU	BACnet MS/TP	Belimo App	Belimo PC-Tool	ZTH EU
VRU-D3-BAC	•	•	-	•	-	D3, dynamic 0...500 Pa	•	•	•	•	•	•	•
VRU-M1-BAC	•	•	-	•	•	M1, diaphragm 0...600 Pa	•	•	•	•	•	•	•
VRU-M1R-BAC	-	-	•	•	•	M1R, diaphragm -75...75 Pa	•	•	•	•	•	•	•



## Installation process



- ▼ [Product overview](#)
- ▼ [Installation](#)
- ▼ [Controllers](#)
- ▼ [Accessories](#)
- ▼ [Parametrization](#)
- ▼ [Diagrams](#)
- ▼ [Maintenance](#)



### RVP-C INSTALLATION

All installation orientations are permitted (except the units with the pressure control components). The volume control accuracy depends on flow conditions before measuring cross. Bends, junctions and narrowings or widenings of the duct cause turbulence and may affect the measurement. For that reason, when installing a damper after a bend or a T-section, it is necessary to ensure long enough straight section of the duct. Recommendations for the length of the straight section of the duct:

- Bend - 1 x Ød
- T-section - 2 x Ød
- Damper - 2 x Ød

Note: All duct fittings (eg. connections, branches etc) should comply with EN 1505.

Installation space is required and should be reserved for installation and maintenance of the VAV dampers. It is necessary to provide access to the inspection openings. Standard RVP-C units come pre-calibrated from

the factory. Standard calibration implies  $V_{nom}$  values that are equivalent to air duct velocity of 12 m/s.  $V_{max}$  and  $V_{min}$  values can be found in the table on [page 2](#).

$V_{min}$  value can be calibrated in a range from 10% of  $V_{nom}$ .  $V_{max}$  can be calibrated in the range between  $V_{min}$  and  $V_{nom}$ . Input signal regulates the volume flow between  $V_{min}$  and  $V_{max}$  linearly. Below  $V_{min}$ , the volume flow cannot be regulated.

**It is possible to order the dampers pre-calibrated from the factory on a lower  $V_{nom}$  setting of 7 m/s.** This consequently lowers the minimum airflow velocity that can be controlled ( $V_{min}$ ) to 0,7 m/s.

If the dampers are installed according to the recommendations, airflow control accuracy depends on the airflow velocity in the duct.

- for velocities > 3 m/s accuracy is declared to ± 5%
- for velocities between 1,2 m/s and 3 m/s accuracy is declared to ± 10%
- for velocities < 1,2 m/s accuracy is declared to ± 20%

Compact VAV actuators with integrated dynamic pressure sensors are intended for use in ventilation systems with relatively clean air. That means that the ventilation systems should not contain abrasive, chemical or adhesive particles. Temperature range in the place of installation is permitted to 0 °C to 50 °C. For regulation in areas with contaminated media, units with static pressure sensors are used (VRU-M1-BAC and VRU-M1R-BAC). These controllers can be calibrated to regulate airflow or pressure in the duct or room.

### Control

Pressure independent VAV's have the following control

parameters:  $V_{min}$  (minimum airflow),  $V_{max}$  (maximum airflow) and  $V_{nom}$  (nominal airflow). These parameters are defining the volume airflow range in which the VAV is operating. Nominal airflow range depends on the size of the damper, and is equal to the corresponding duct air velocity of 12 m/s.

$V_{min}$  can be set to any volume airflow between 10% $V_{nom}$  and 100% $V_{nom}$ , and  $V_{max}$  can be set to any volume airflow between  $V_{min}$  and  $V_{nom}$ . On special demand a VAV actuator can be parametrized to  $V_{nom} = 7$  m/s in case of

low volume airflow applications. The control of the dampers is done via analog signal (0(2)-10V) or some of the supported communication protocols. Most commonly a BMS system is controlling the ventilation system (including the VAV's), but it is possible for the VAV's to work independently with a simple room controller providing it with the needed setpoint.

Except stand-alone operation, VAV's can work in parallel operation and master/slave operation. In parallel operation control signals are always the same, and control parameters  $V_{min}/V_{max}$  can be set independently. In master/slave operation the actual signal from the master unit is controlling the reference air volume in the slave unit. Actuators are overload proof. Compact, standard and high speed actuators will remain at their last position in the event of power shutdown. Spring return actuators will completely close or open the damper, depending on their installation orientation.

Parametrization is made in the factory according to the customer demands or default settings. Subsequently changes to the parametrization can be made on site with ZTH tool or Belimo assistant app.



## Belimo motor drive

- motor drives : Belimo (MP, ModBus/Bacnet, MF, KNX)
- power supply - AC 24V, 50/60 Hz  
- DC 24V
- diagnostic socket for service and PC-Tool software

Type	Torque	Energy consumption	Dimensioning	Weight
LMV-D3-MP	5Nm	2W	4VA (max- 8A @ 5ms)	≈ 500g
NMV-D3-MP	10Nm	3W	5VA (max- 8A @ 5ms)	≈ 700g
LMV-D3-MOD/BAC	5Nm	2W	4VA (max- 8A @ 5ms)	≈ 500g
NMV-D3-MOD/BAC	10Nm	3W	5VA (max- 8A @ 5ms)	≈ 700g
LMV-D3-MF	5Nm	2W	4VA (max- 8A @ 5ms)	≈ 500g
LMV-D3-KNX	5Nm	2W	4VA (max- 8A @ 5ms)	≈ 500g
NMV-D3-KNX	10Nm	3W	5VA (max- 8A @ 5ms)	≈ 700g

### Control variables

Vnom	specific nominal volume flow, suitable for VAV units
$\Delta p @ V_{nom}$	50...450 Pa
Vmax	20...100%
Vmin	0...100%
Vmid	50% od Vmin do Vmax

### Classic control

VAV mod for referent variables Y (connection 3)	- DC 2...10V / (4...20mA with 500 $\Omega$ impedance) - DC 0...10V / (0...20mA with 500 $\Omega$ impedance) }input impedance min. 100 kOhm - Adjustable DC 0...10V
Actual signal value mod U5 (connection 5)	- DC 2...10V - DC 0...10V } max. 0.5 mA - Adjustable : volume flow, damper position or differential pressure
CAV mode (constant volume flow)	CLOSED / Vmin / Vmid / Vmax / OPEN* (*only with AC 24V supply)

### Actuator

Connection	Cable, 4 x 0,75 mm <sup>2</sup>
Protection	
Safety class	III Safety extra - low voltage
Level of protection	IP54
Electromagnetic compliance	CE according to 89/336/EEC
Mode	Type 1 (according to EN 60730-1)
Rated power	0,5kV (according to EN 60730-1)
Operating temperature	0...+50 °C
Non operating temperature	-20...+80 °C
Relative humidity	5...95% r.h., no condensation (according to EN 60730-1)
Maintainance	Not required

- ▼ [Product overview](#)
- ▼ [Installation](#)
- ▼ [Controllers](#)
- ▼ [Accessories](#)
- ▼ [Parametrization](#)
- ▼ [Diagrams](#)
- ▼ [Maintenance](#)

**Operation specification:**

Rated voltage	DC 15 V (from regulator VRP...)		
Voltage range	DC 13,5...16,5 V		
Mesuring range	0...100 Pa 0...300 Pa 0...600 Pa		
Mesuring principle	Inductive membrane differential presure mesurement		
Output signal	DC 0...10 V (proportional pressure for VRP..)		
Linearity	±1% from extreme value (FS)		
Histeresis	0,1% typ.		
<b>Temperature influence</b>			
zero position	±0,1% / K	±0,05% / K	±0,05% / K
Mesuring range	±0,1% / K t = +10...+40°C (referent temperature to = 5 °C)		
Installation position	Vertical		
Position dependance	Max. ±4,5 Pa za 90° rotation from horizontal		
Electric connection	Cable 1 m , with 4 pole connector		
Protection class	III (safety extra-low voltage) IP4		
Operating temperature	0...+50 °C		
Storage temperature	0...+80 °C		
Humidity test	to EN 60335-1		

- ▼ [Product overview](#)
- ▼ [Installation](#)
- ▼ [Controllers](#)
- ▼ [Accessories](#)
- ▼ [Parametrization](#)
- ▼ [Diagrams](#)
- ▼ [Maintenance](#)

**Wiring diagram**

Analog control signal

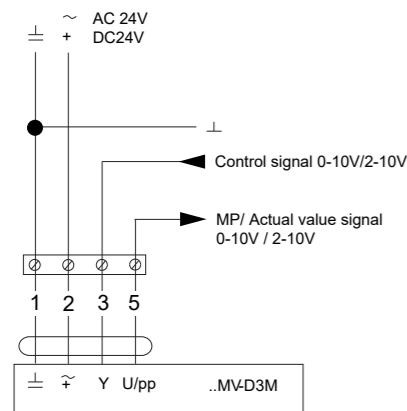

Analog control signal supply/extract in paralel mode

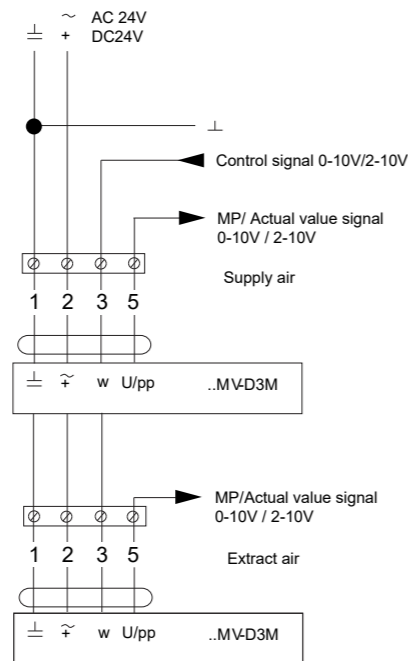

Analog control signal master / slave mode

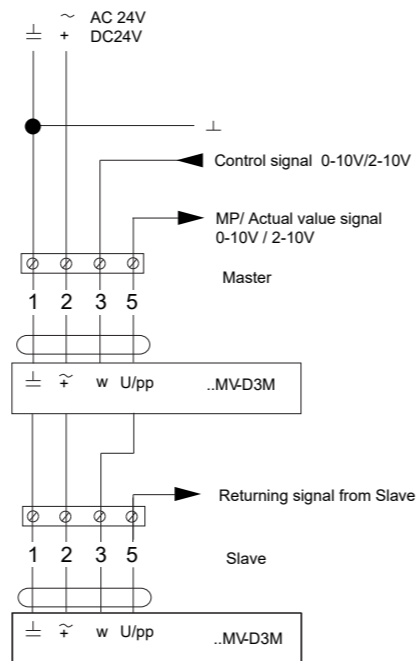

Constant mode:  
- Standard 0,1V closing

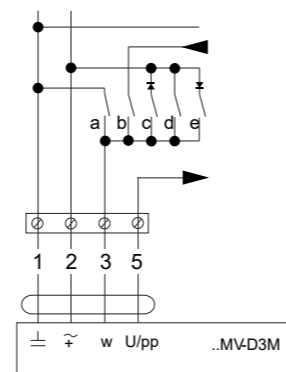

RVP-C ACTUATORS

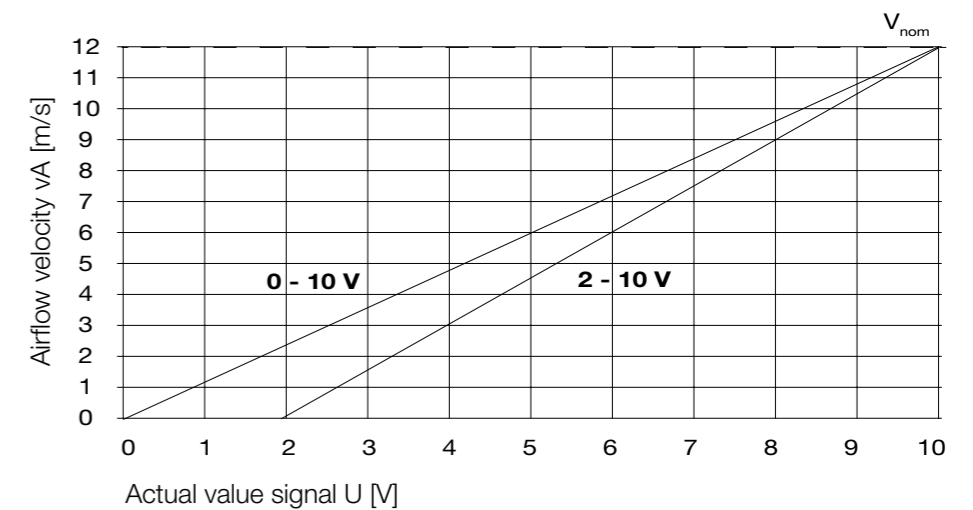

$$0 - 10 \text{ V} \quad V_{act} = \frac{U_{act} - V_{nom}}{10}$$

$$2 - 10 \text{ V} \quad V_{act} = \frac{U_{act} - 2}{8} * V_{nom}$$



## Siemens motor drive

- motor drives : Siemens (KNX, ModBus, Bacnet, Analogue)
- power supply: AC 24 V ±20% 50/60 Hz

Type	Torque	Energy consumption	Dimensioning	Weight
GDB181.1E/3	5Nm	2W	4VA (max- 8A @ 5ms)	≈ 500g
GLB181.1E/3	10Nm	3W	5VA (max- 8A @ 5ms)	≈ 700g
GDB181.1E/MO	5Nm	2W	4VA (max- 8A @ 5ms)	≈ 500g
GLB181.1E/MO	10Nm	3W	5VA (max- 8A @ 5ms)	≈ 700g
GDB181.1E/BA	5Nm	2W	4VA (max- 8A @ 5ms)	≈ 500g
GLB181.1E/BA	10Nm	3W	5VA (max- 8A @ 5ms)	≈ 700g
GDB181.1E/KN	5Nm	2W	4VA (max- 8A @ 5ms)	≈ 500g
GLB181.1E/KN	10Nm	3W	5VA (max- 8A @ 5ms)	≈ 700g

- ▼ [Product overview](#)
- ▼ [Installation](#)
- ▼ [Controllers](#)
- ▼ [Accessories](#)
- ▼ [Parametrization](#)
- ▼ [Diagrams](#)
- ▼ [Maintenance](#)

### Damper actuator

Normal torque	5 Nm (GDB) / 10 Nm (GLB)
Maximum torque	<7 Nm (GDB) / <14 Nm (GLB)
Normal rotation angle / maximum rotation angle	90° / 95° ±2°
Running time for normal rotation angle 90°	150 s (50Hz) / 125 s (60Hz)
Direction of rotation (Adjustable with e.g. ACS941)	Clockwise / Counterclockwise
<b>Signal inputs</b>	
Input voltage	DC 0/2 ... 10 V
Max. perm input volume	DC 35 V
Contact Sensing	
Contact open	DC 30 V contact voltage
Contact closed	DC 0 V, 8 mA contact current
<b>Signal outputs</b>	
Output voltage	DC 0/2 ... 10 V limited to DC 12 V
Max. output current	DC ±1 mA
Time constant (actual value U)	0,05...5 s
Resolution 0.01 S / factory settin 1 s	
<b>Degree of protection and safety class</b>	
Degree of protection acc. to EN 60529 (cf. mounting instructions)	IP54
Safety class acc. to EN 60730	6 x 0.75 mm <sup>2</sup>
<b>Enviromental conditions</b>	
Operation / transport	IEC 721-3-3 / IEC 721-3-2
Temperature	0 ... 50 °C / -25...70 °C
Humidity (non-condensing)	<95% r.h. / <95% r.h.



RVP-C ACTUATORS



Air volume controller	
3-position controller with hysteresis	
V <sub>max</sub>	20 ... 100%
V <sub>min</sub>	-20 ... 100%
V <sub>mid</sub>	0 ... 100%
V <sub>n</sub>	1...3.16
Differential pressure sensor	
Connection tubes (inerior diameter)	3 ... 8 mm
Measuring range	0 ... 500 Pa
Operation range	0 ... 300 Pa
Precision at 23°C, 966 mbar and optional mounting position	
Zero point	± 0.2 Pa
Amplitude	± 4.5 of the measured value
Drift	± 0.1 Pa / Year
Max. permissible operation pressure	3000 Pa
Max. permissible overload on one side	3000 Pa
Connection cable	
Cable length	0.9 m
Number of cores and cross-sectional area	6 x 0.75 mm <sup>2</sup>

- ▼ [Product overview](#)
- ▼ [Installation](#)
- ▼ [Controllers](#)
- ▼ [Accessories](#)
- ▼ [Parametrization](#)
- ▼ [Diagrams](#)
- ▼ [Maintenance](#)

## Wiring diagram

Supply / extract air control in operating mode "con"  
 N1 GDB181.1E/3 or GLB181.1E/3  
 N2 Supervisory controller, e.g. RCU5.. or RCU6.

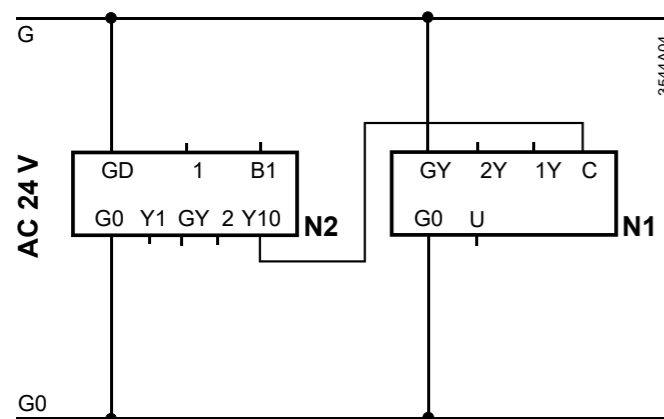

Supply / extract air control in operating mode "con"

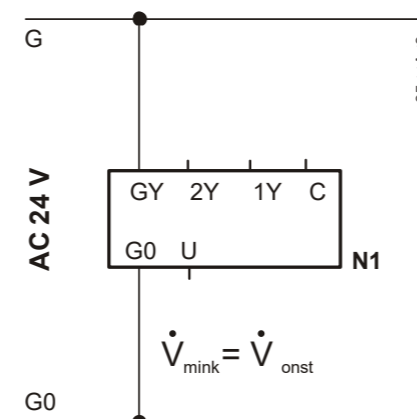

Complete shutoff in operating mode "con"  
 N1 GDB181.1E/3 or GLB181.1E/3  
 S1 Window switch (Window closed – switch open)

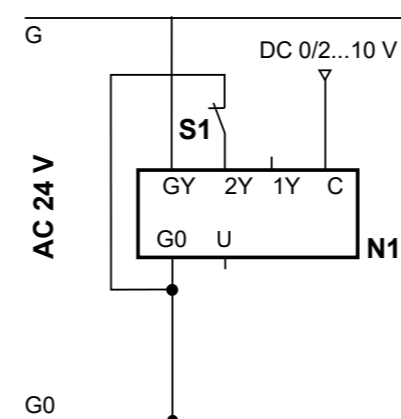

## RVP-C ACTUATORS



## Gruner motor drive

- motor drives : Gruner (327V)
- Running time 100 s / 90°, 150 s / 90°
- Torque 5 -10 - 15 Nm
- Nominal voltage 24 VAC/DC
- Control 3 (EN 60730-1)
- Sensor 250 Pa (dynamic)
- Communication Modbus RTU

- ▼ [Product overview](#)
- ▼ [Installation](#)
- ▼ [Controllers](#)
- ▼ [Accessories](#)
- ▼ [Parametrization](#)
- ▼ [Diagrams](#)
- ▼ [Maintenance](#)

Damper actuator	
Nominal voltage	24 VAC/DC, 50/60 Hz
Nominal voltage range	19...29 VAC/DC
Power consumption motor (motion)	3 W
Power consumption standby (end position)	2 W
Wire sizing	5,5 VA
Control	Modbus RTU / analog (0)2...10 VDC / Ri > (100 kΩ) 50 kΩ (0)4...20 mA / Rext. = 500 Ω
Feedback signal	Modbus RTU / analog (0)2...10 VDC, max. 0,5 mA
Priority control	close / min / btw / max / open / stop
Connection motor	cable 1000 mm, 4 x 0,75 mm <sup>2</sup> (halogen free)
Sensor	
Measuring range - dynamic version	500-1500 Pa
Measuring range - static version	400-600-1000 Pa
Burst pressure	1 bar
Nominal value damper manufacturer specific value	damper manufacturer specific value Vmin / Vbtw / Vmax based on Vnom
Media	air -40°C...85°C / 5...95% r.H., non condensing
Mounting position	independent of position
Connection	tube clip Ø 4-6 mm
Functional data	
Torque	5 -10 - 15 Nm
Synchronised speed	±5%
Direction of rotation	adjustable



Manual override	gear de-clutch with pushbutton, lockable
Angle of rotation	0°...max. 95° can be limited with adjustable mechanical end stops
Running time	5 Nm: 100 s / 90° (adjustable 20...120 s / 90°) 10 & 15 Nm: 150 s / 90° (adjustable 70...420 s / 90°)
Sound power level	< 35 dB(A) @ standard running time
Shaft coupling	universal clamp (Ø 20 mm) or form fit □ 8/10/12 mm
Position indication	mechanical with pointer
Service life	> 100 000 cycles (0°...95°...0°) > 1 500 000 partial cycles (max. ±5°)

Safety	
Protection class	III (safety extra-low voltage)
Degree of protection	IP 42 (cable downwards, tube clip connected) IP 20 (with screw terminals)
EMC	CE (2014/30/EU)
LVD	CE (2014/35/EU)
RoHS	CE (2011/65/EU - 2015/863/EU - 2017/2102/EU)
Mode of operation	Typ 1 (EN 60730-1)
Rated impulse voltage	0,5 kV (EN 60730-1)
Control pollution degree	3 (EN 60730-1)
Ambient temperature normal operation	0 °C...+50 °C
Storage temperature	-20 °C...+80 °C
Ambient humidity	5...95% r.H., non condensing (EN 60730-1)
Maintenance	maintenance free
Dimensions	
Dimensions	155 x 67 x 66 mm
Weight	5 Nm: 450 g 10/15 Nm: 550 g

- ▼ [Product overview](#)
- ▼ [Installation](#)
- ▼ [Controllers](#)
- ▼ [Accessories](#)
- ▼ [Parametrization](#)
- ▼ [Diagrams](#)
- ▼ [Maintenance](#)

RVP-C ACTUATORS

## Wiring diagram

### VAV

– variable operation min ... max

-Mode 2-10V:

Damper closed < 0,8 V (adjustable via WIN-VAV2 0,2 V ... 1,8 V)

-Master/Slave circuit possible

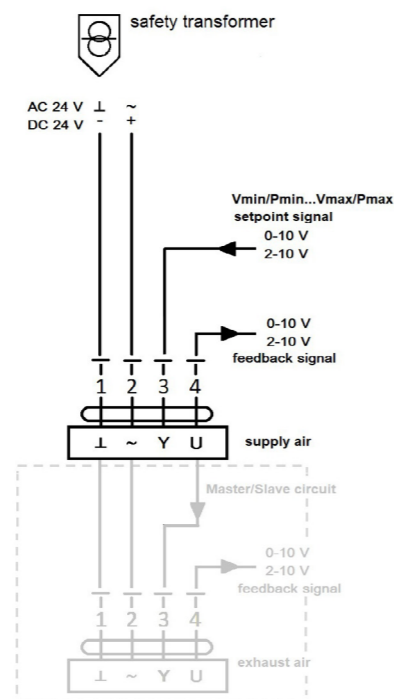

### CAV

– step operation close / min / btw / max / open

Signal/ Function	Min	Max	Btw	Open	Close
Open line	X				
GND (2.10 V)					X
Full wave		X		X	
Pos. Hal-wave				X	
Neg. Hal-wave					X

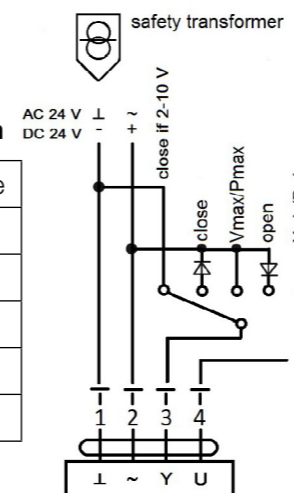

## Accessories

### CODIS E35-VAV

Codis 35 helps control ventilation more efficiently by demanding just the right amount of fresh air needed for optimal indoor conditions. Device can be used for temperature, air quality and humidity control



### BELIMO Parametrization

Adjustment device ZTH-EU and NFC for VAV terminal units with Belimo volume flow controllers, used to facilitate service and commissioning.

**ORDERING KEY: RVPA-ZTH-EU**



### Gruner GUIV3-M

Adjustment device GUIV3-M for VAV terminal units with Gruner volume flow controllers, used to facilitate service and commissioning.

**ORDERING KEY: RVPA-GUIV3-M**



### Siemens AST20

Adjustment device Type AST20 for VAV terminal units with Siemens volume flow controllers, used to facilitate service and commissioning.

**ORDERING KEY: RVPA-AST20**



- ▼ [Product overview](#)
- ▼ [Installation](#)
- ▼ [Controllers](#)
- ▼ [Accessories](#)
- ▼ [Parametrization](#)
- ▼ [Diagrams](#)
- ▼ [Maintenance](#)



## ACCESSORIES

### ORDERING KEY ACCESSORIES CODIS E35

(1) Type      (2) Built in sensor      (3) Protocol

**E35 - VAV - H - B/RS**

(1) **E35 - VAV**

(2) **C** - CO2 sensor  
**H** - Humidity sensor  
**CH** - CO2 and humidity sensor

(3) **B/RS** - BACNet

# CODIS E35

Device can be used for temperature, air quality and humidity control of individual zones as part of a Demand Controlled Ventilation system, HVAC system or as a standalone controller.

E35-VAV... can be used in HVAC systems for:

- Heating
- Cooling
- Ventilation
- Dehumidification



1

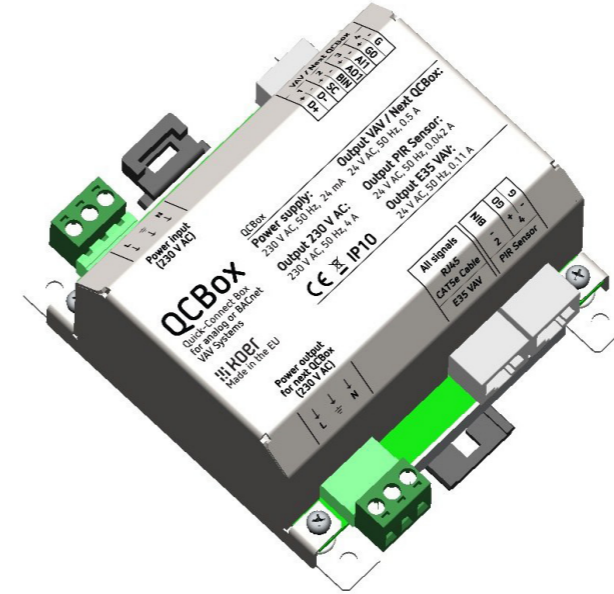

2

MODEL	E35-VAV	E35-VAV-B/RS	E35-VAV-C	E35-VAV-C-B/RS	E35-VAV-H	E35-VAV-H-B/RS	E35-VAV-H-C	E35-VAV-H-C/RS	QCB	QCAdapter
Description	Temperature	Temperature BACNet / RS485	Temperature CO2	Temperature CO2 BACNet / RS485	Temperature Humidity	Temperature Humidity BACNet / RS485	Temperature Humidity CO2	Temperature Humidity CO2 BACNet / RS485	Quick connect box with power supply	Quick-Connect Adapter

- ▶ Product overview
- ▶ Installation
- ▶ Controllers
- ▶ Accessories
- ▶ Parametrization
- ▶ Diagrams
- ▶ Maintenance

## ACCESSORIES

## AIRFLOW REGULATION

E35-VAV... can control of the following operational elements:

- Damper actuators
- Heat exchange actuators
- Radiator/Floor heating actuator
- Modulating electric heaters
- EC motor fanT

E35-VAV hardware features:

- Resistive Color TFT touchscreen display
- Built-in sensors:
  - Temperature
  - CO2 (optional)
  - Relative Humidity (optional)
- Three analog 0...10 V DC outputs
- One analog 0...10 V DC input
- One analog resistive input
- One binary input
- RS-485 transceiver (optional)
- Galvanic isolated RS-485 transceiver (optional)
- Real Time Clock
- Easy wall mounting
- Power supply 24 V AC/DC

E35-VAV software features:

- PID control based on temperature, air quality and \* humidity parameters
- Weekly scheduler, four preset modes, up to eight scheduler timers per day
- Occupied mode function
- Three operating modes: Comfort, Economy, Standby
- Protection functionality in Standby mode
- Password protected menu and advanced menu
- Window contact or presence sensor input
- Automatic or manual changeover
- Standby, Dim and Night Mode display brightness
- Easily configurable commissioning and working parameters
- Setpoint limitations for users
- BACnet MS/TP communication protocol (optional)
- Internal Temperature Compensation Algorithm

For more details:

- (1) [CODIS E35 VAV](#)
- (2) [QCB Quick-Connect Box](#)

### WIRING SCHEME

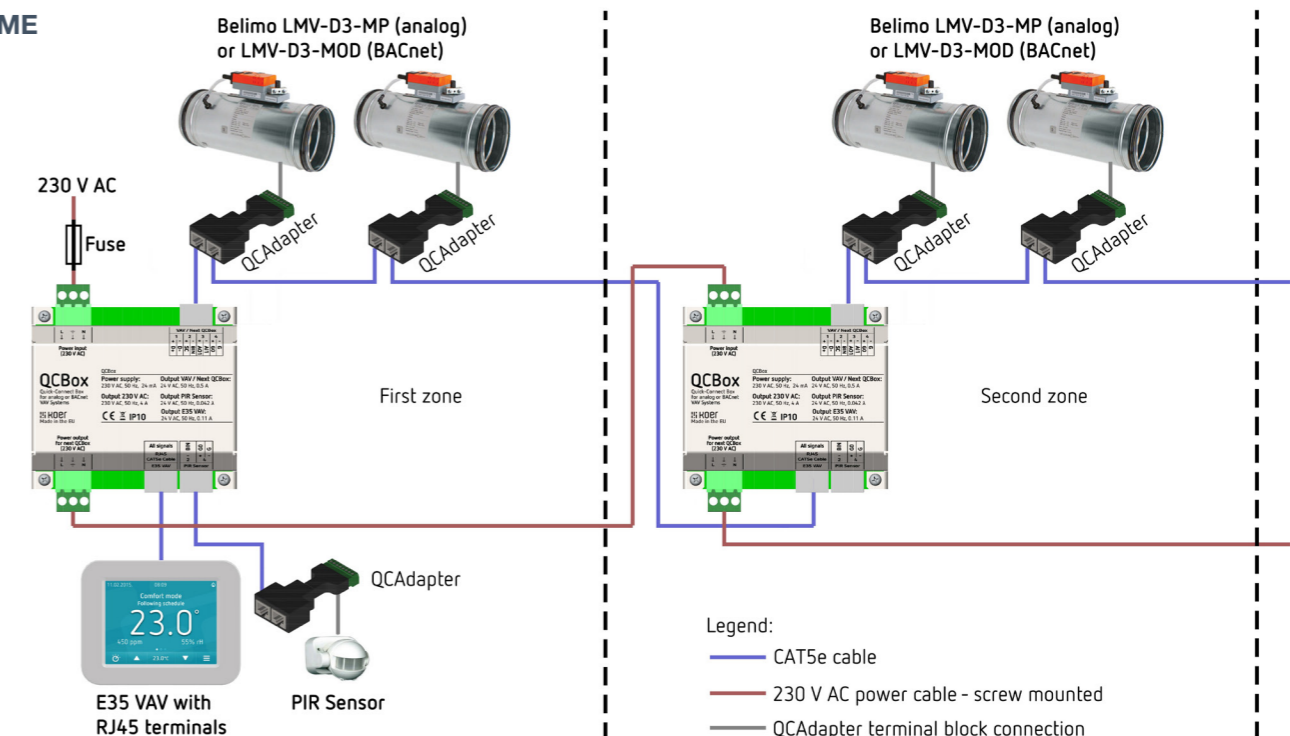

# ZTH

Adjustment device ZTH-EU for VAV terminal units with Belimo volume flow controllers, used to facilitate service and commissioning. Service tool for parameterisable and communicative actuators / VAV controllers and HVAC performance devices from Belimo. Connection via service socket on the device or MP/PP connection ZIP USB function.

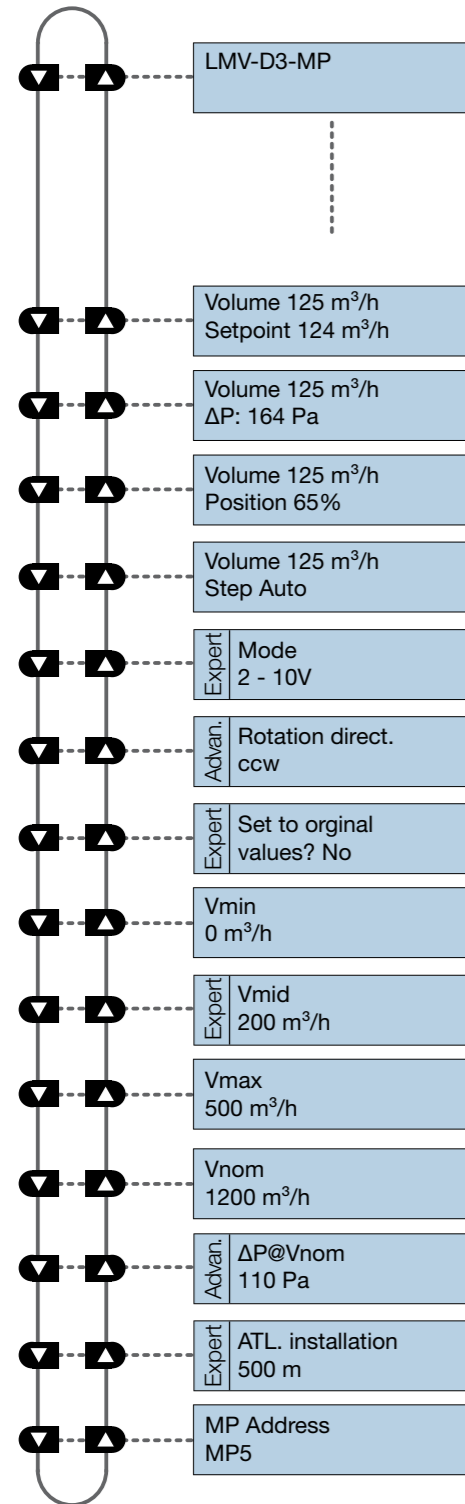
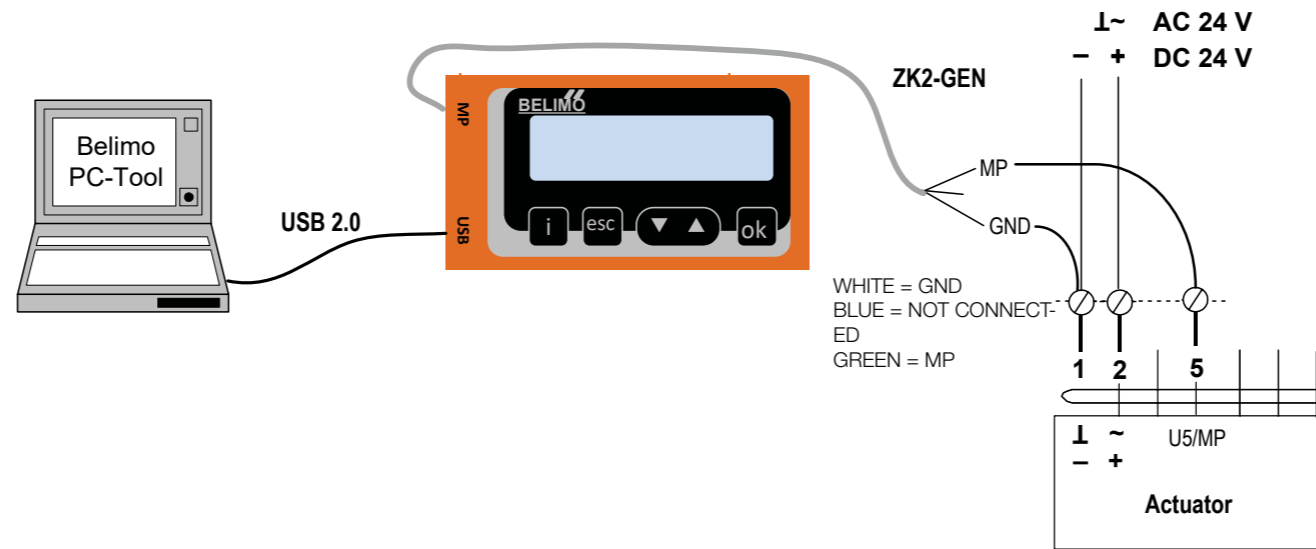

## Instructions

Pressing the buttons , you scroll through the main menu. In order to prepare the selected values (parameters), it is necessary to follow the steps in the picture.

AUTO / OPEN / CLOSE / Min / Mid / Max / Stop

2 - 10V / 0 - 10V (only with MF/MP types)

ccw / cw

No / Yes

0...Vmax





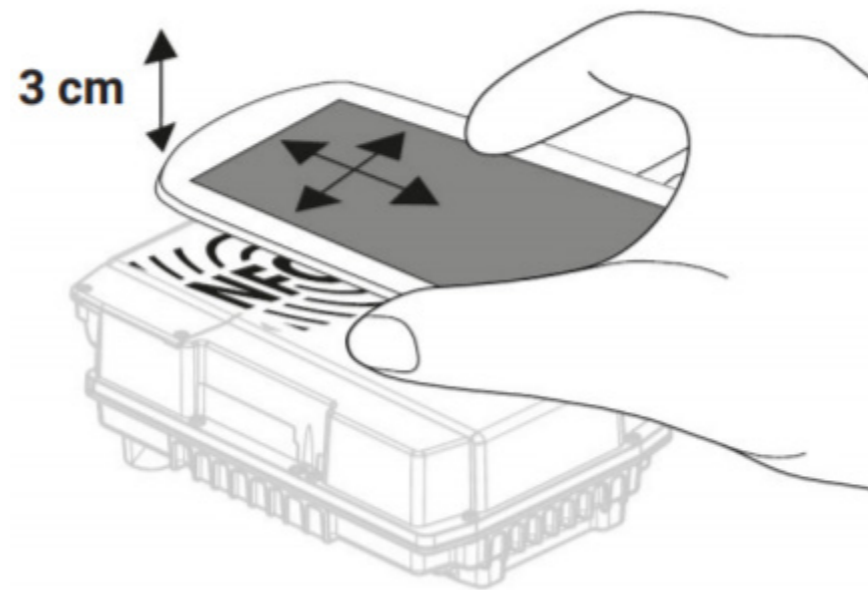

Vmin...Vmax

Vmin...Vnom, minimum 20% of Vnom

0...3000 m

PP, MP1...MP8  
(on MF types only PP)



-  [Product overview](#)
-  [Installation](#)
-  [Controllers](#)
-  [Accessories](#)
-  [Parametrization](#)
-  [Diagrams](#)
-  [Maintenance](#)

## BELIMO NFC

The integrated NFC interface (Near Field Communication) of the VAV-Compact and VAV-Universal controllers allows you to use the system with your own smartphone – for simple and efficient commissioning and configuration – wirelessly with the Belimo Assistant App.

The ZIP-BT-NFC is available for connection via Bluetooth. For configuration at the VAV unit manufacturer (OEM) or during commissioning for bus addressing, both also in a de-energised state. Simple operational check thanks to the graphical trend analysis.

## GUIV3-M

GUIV will start via on/off switch. If GUIV is connected to an actuator, the data will be read out and shown in the display. The control panel is used to set various operating modes, override controls and parameter settings. The GUIV features a micro USB. This allows to use the GUIV as an interface converter between WINVAV2 software and actuator or for loading a battery pack.

### Instructions

To perform parameterization, it is necessary to connect the drive with the adjustment device GUIV3-M.

The adjustment device contains a circular button and a confirmation button. With circular button you scroll through the main menu and you can change the values (parameters).

### Menu points GUIV3-M

1.Act / Set

Shows actual value / setpoint (override function).

2.Min

Adjust the desired min value (setpoint Y = 0 / 2 V DC).

3.Max

Adjust the desired max value (setpoint Y = 10 V DC).

4.Diag

Diagnostic menu:

y/u – shows setpoint / feedback signal

off – return to first level

oP – opens the damper

cL – closes the damper

Hi – activates max. value

Lo – activates min. value

bE – activates between value

St – diagnostic mode on, motor off

Adp – adaption drive (only 15 Nm or Modbus version)

123 – software version

5.Mode

0An (0-10 VDC | normal direction of rotation) 2An (2-10

VDC |normal direction of rotation)

2Ai (0-10 VDC | inverse direction of rotation) 2Ai (2-10 VDC |

inverse direction of rotation)

6.Com

Setting the Modbus address (1...247) and communication parameters (if Modbus version).

7.Nom

Volumetric air flow: Shows & setting the nominal value depending on the VAV-Box

Pressure: Setting the correction factor

Settings

327 VAV actuators can be set directly on the display. All 327

VAV actuators can communicate via service connector with

setting tool GUIV3-M or with setting software WIN-VAV2.

GUIV3-S is used as an interface for setting software WIN-VAV2.

Accessories

GUIV3-M – service connector + handheld tool GUIV3-M

WINVAV2-Bundle – service connector + PC interface GUIV3-S

+ setting software WIN-VAV2.

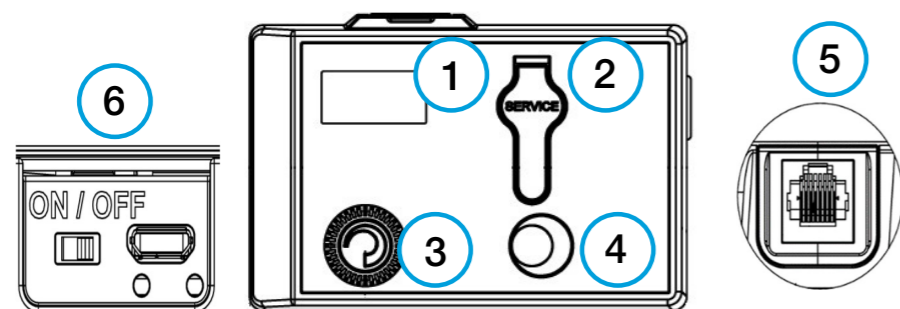

1. Display
2. Port for service-plug
3. Rotary selector switch
4. LED push button
5. RJ45 socket
6. On/off Switch and Micro-USB Interface

- ▼ [Product overview](#)
- ▼ [Installation](#)
- ▼ [Controllers](#)
- ▼ [Accessories](#)
- ▼ [Parametrization](#)
- ▼ [Diagrams](#)
- ▼ [Maintenance](#)

## PARAMETRIZATION

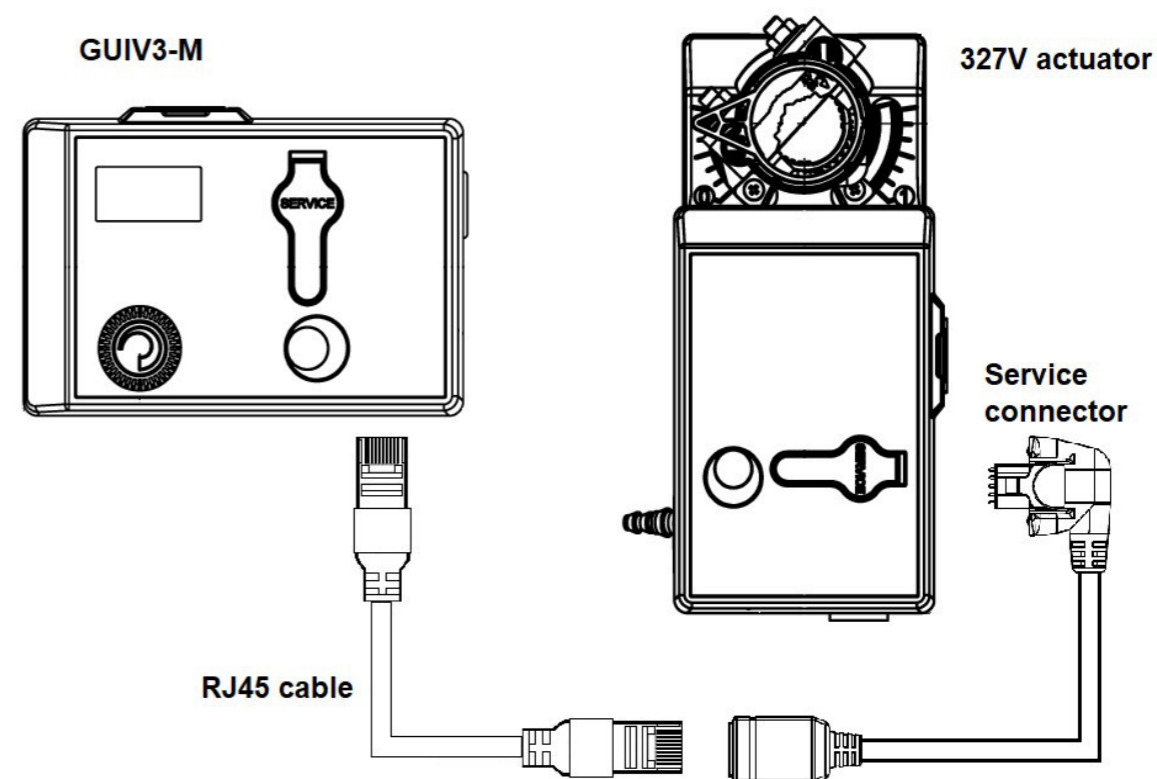

# AST20

## Instructions

Pressing the UP/DOWN buttons, you scroll through the main menu.

Button ENTER opens submenu or allows changing the selected value using UP/DOWN button.

The pictures show the way of changing the values (parameters).

AST20 <> VAV Modbus	1/1 SVC
Online view	▶
Field device configuration	▶
Bus configuration	▶
Diagnostics and maintenance	▶
AST20 settings	▶
Mass configuration	▶

Field device configuration	1/2 SVC
Operating mode	VAV mode
Opening dir	CW
Adaptive pos	On
Vn value	2.04
Vmin	10%
Vmax	90%
Vnom	450 m3/h

Field device configuration	1/2 SVC
Operating mode	VAV mode
Opening dir	CW
Adaptive pos	On
Vn value	2.04
Vmin	10%
Vmax	90%
Vnom	450 m3/h

Field device configuration	1/2 SVC
Operating mode	VAV mode
Opening dir	CW
Adaptive pos	On
Vn value	2.04
Vmin	10%
Vmax	90%
Vnom	450 m3/h

## AST20

1. AST20
2. G..B181.1E/.. , ASV181.1E/3, or G..B111../MO
3. Strain release strip
4. Connection cable (7-pin or 6-pin)

Handheld Tool for VAV Compact Controllers and Communicative Actuators. For configuration and maintenance of OpenAir VAV compact and modular controllers and actuators with Modbus RTU communication

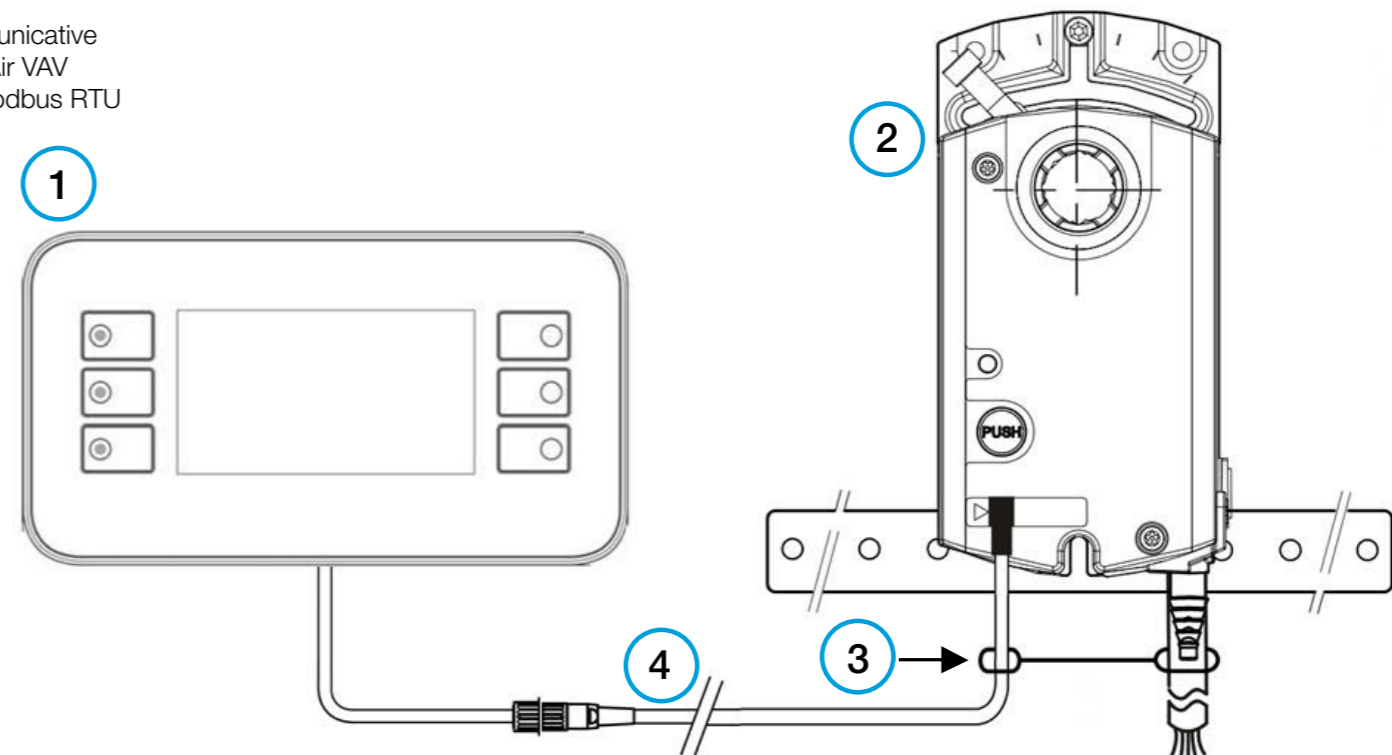

- ▶ [Product overview](#)
- ▶ [Installation](#)
- ▶ [Controllers](#)
- ▶ [Accessories](#)
- ▶ [Parametrization](#)
- ▶ [Diagrams](#)
- ▶ [Maintenance](#)

## ↻ PARAMETRIZATION



# Quick selection diagrams

## RVP-C Ød100 - Ød315

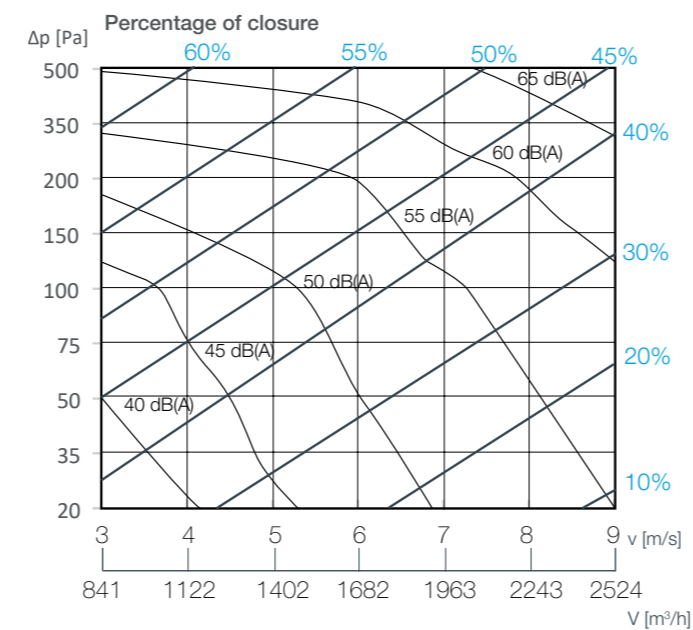
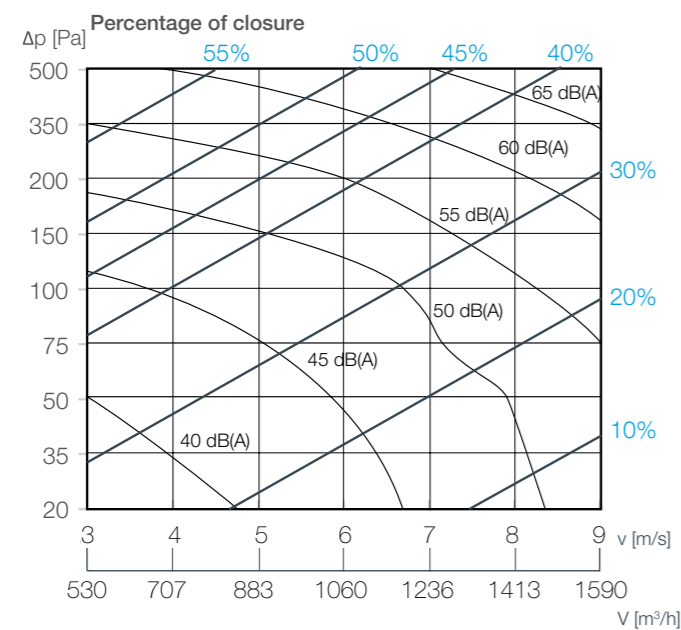
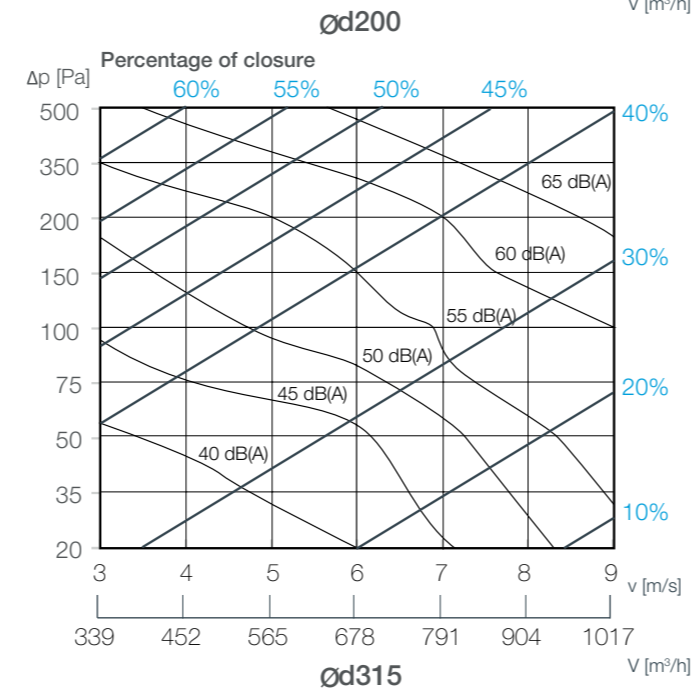
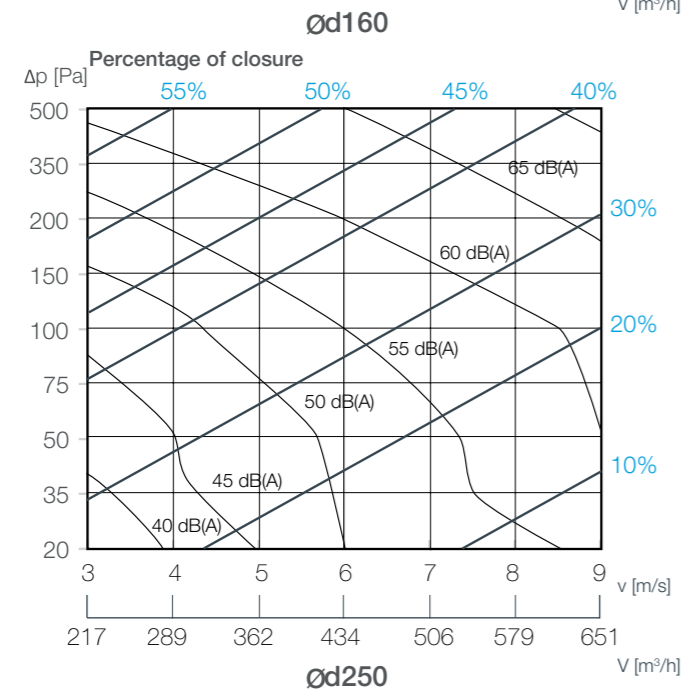
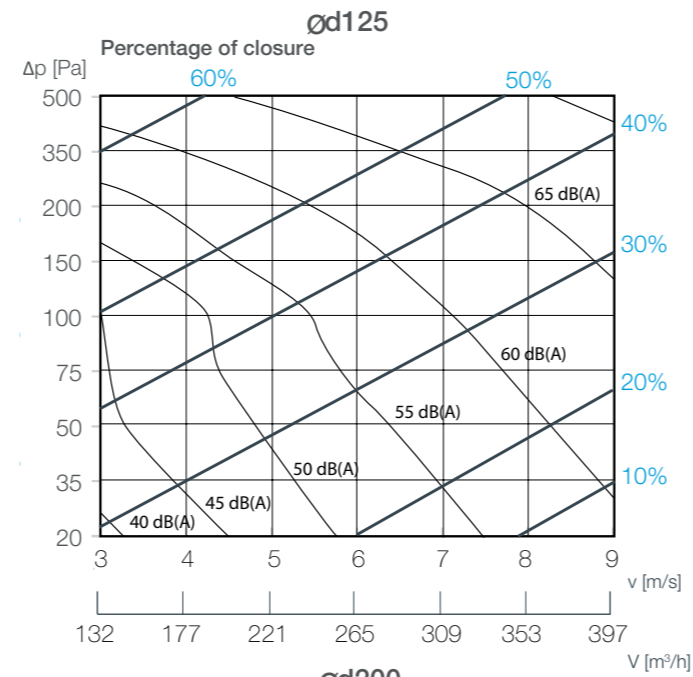
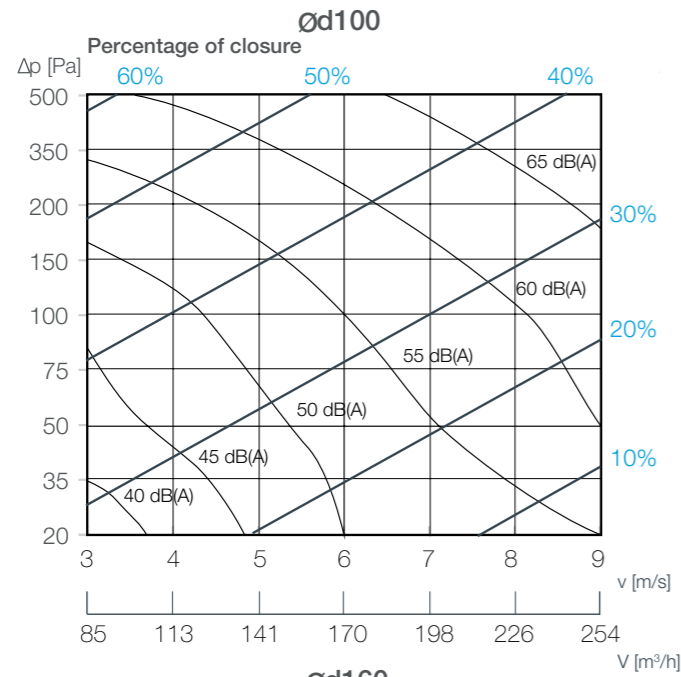

- ▼ [Product overview](#)
- ▼ [Installation](#)
- ▼ [Controllers](#)
- ▼ [Accessories](#)
- ▼ [Parametrization](#)
- ▼ [Diagrams](#)
- ▼ [Maintenance](#)



[SolveAir link](#)

### RVP-C DIAGRAMS

Quick selection diagrams  
RVP-C Ød400 - Ød630

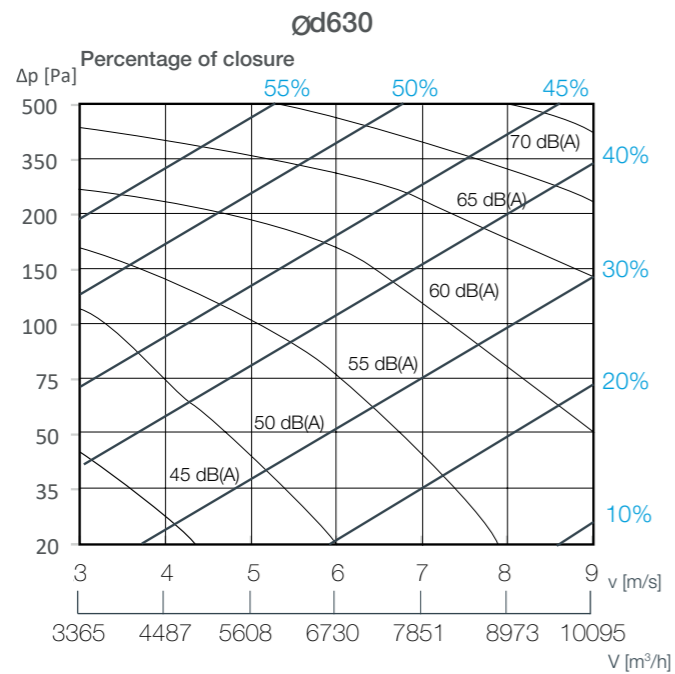
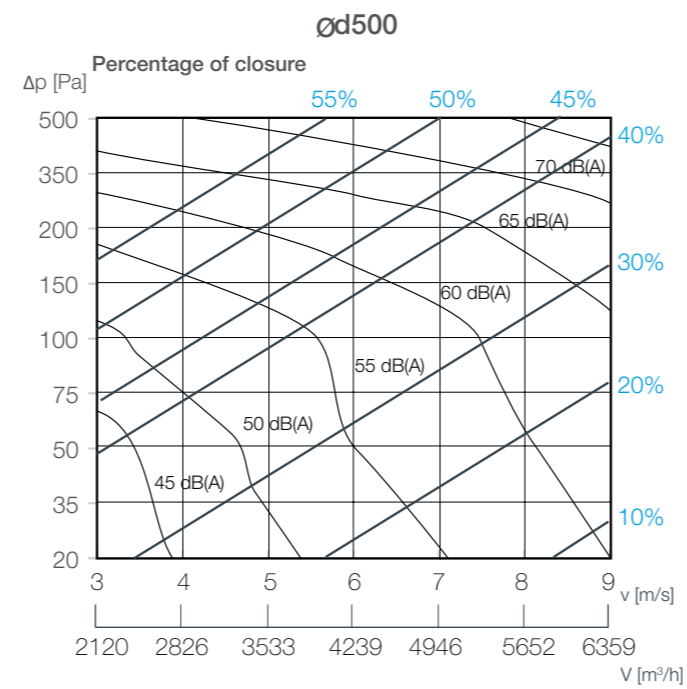
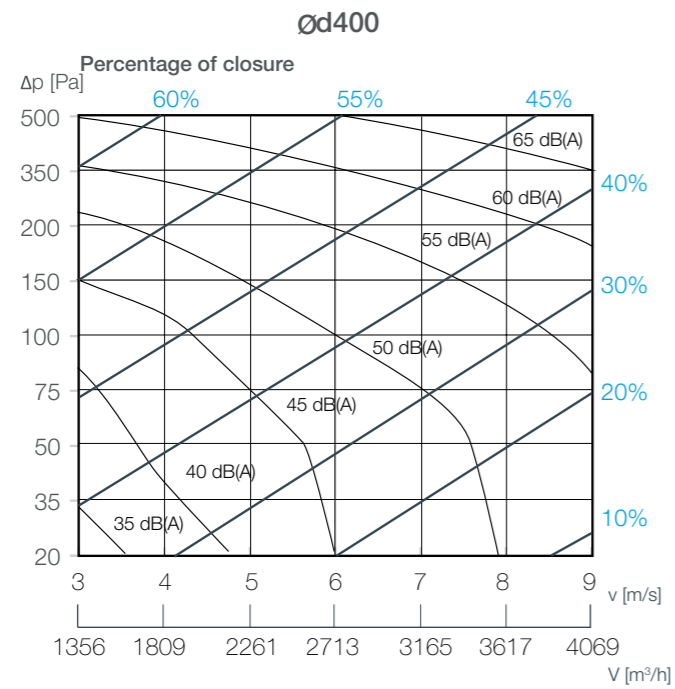

- ▼ [Product overview](#)
- ▼ [Installation](#)
- ▼ [Controllers](#)
- ▼ [Accessories](#)
- ▼ [Parametrization](#)
- ▼ [Diagrams](#)
- ▼ [Maintenance](#)



[SolveAir link](#)

RVP-C DIAGRAMS



- ▼ [Product overview](#)
- ▼ [Installation](#)
- ▼ [Controllers](#)
- ▼ [Accessories](#)
- ▼ [Parametrization](#)
- ▼ [Diagrams](#)
- ▼ [Maintenance](#)



## TRANSPORT

After arrival, check the VAV damper for transport damage and shortcomings. In case of any damage or shortcomings, immediately contact your supplier.

## STORAGE

If the damper is not installed immediately:

- Remove any wrapping.
- Protect VAV damper from dust and contamination.
- Do not expose the fire damper to the effects of weather - store VAV damper in a dry place.
- Do not store the unit below -20 °C or above 50 °C.

Please properly dispose of packaging material!

## MAINTENANCE AND OPERATION

Klimaoprema VAV dampers are designed with fully enclosed drive mechanism outside of the duct and as such do not require cleaning and regular maintenance. However, activation mechanism should be inspected for proper operation on regular basis.

- Provide at least one annual check of the damper
- After each intervention, provide a systematic cleaning of dust and especially the solenoid and its movable plate
- Check the if the electrical terminals are tightened
- Cleaning instruction: clean with a sponge, with water or a mild detergent
- Disinfection instruction: spray disinfectant (disinfectant may contain alcohol which is flammable, take precaution to avoid ignition)

It is not permitted to alter the dampers in any way nor perform any changes to their structure (except for the service procedures described in this manual) without the manufacturer's consent.

Provide at least one annual check of the damper. The functional test must be carried out in compliance with the basic maintenance principles of the European norms EN 13306, EN 15423 and EN15650.

## COMMISSIONING

- 1) Carefully unpack RVP-C - be careful of sharp edges and do not use excessive force for unpacking
- 2) Inspect the product - check the volume flow damper for damage
- 3) Installation of the volume flow damper - according to the installation instructions ([page 13.](#))
- 4) Before commissioning: check the product functions

## FUNCTIONS

- 1) Electric actuator:  
Signal testing - the damper blade must close/open



## AIRFLOW REGULATION

---

Projektiranje, proizvodnja i održavanje opreme za klimatizaciju, ventilaciju i čiste prostore.  
Design, production and service of Ventilation, Air-Conditioning and Cleanroom equipment.

---

 Gradna 78A, 10430 Samobor, Croatia  
 +385 (0)1 33 62 513  
 [info@klimaoprema.com](mailto:info@klimaoprema.com)  
 [www.klimaoprema.com](http://www.klimaoprema.com)